



PennState Extension

Online Tool for Designing Ventilation Systems to Reduce Manure Pit Entry Risk

Harvey B. Manbeck, PhD, PE (Instructor & Project Consultant)

Dan Hofstetter, M.S., PE (Research Associate and PhD Candidate)

Dennis J. Murphy, PhD, CSP (PI)

Virendra M. Puri, PhD (Cooperator)

Penn State University
www.agsafety.psu.edu



Penn State Extension

Online CFD Tool for Designing Ventilation Systems to Reduce Manure Pit Entry Risk

- The Ag Safety Problem
- Manure Pit Safety Program Vision
- Prior Work & Limitations
- Overview of the Online Tool
- Design Example
- Introduce Online Workshop

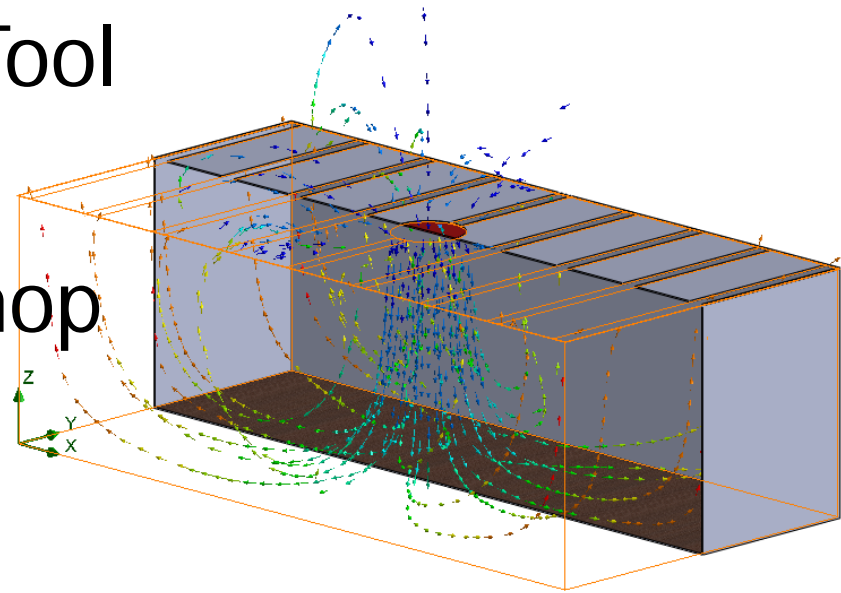



Slatted Floor

exit; an

are Confined Spaces

h and so configured that an
can bodily enter and perform
work: and

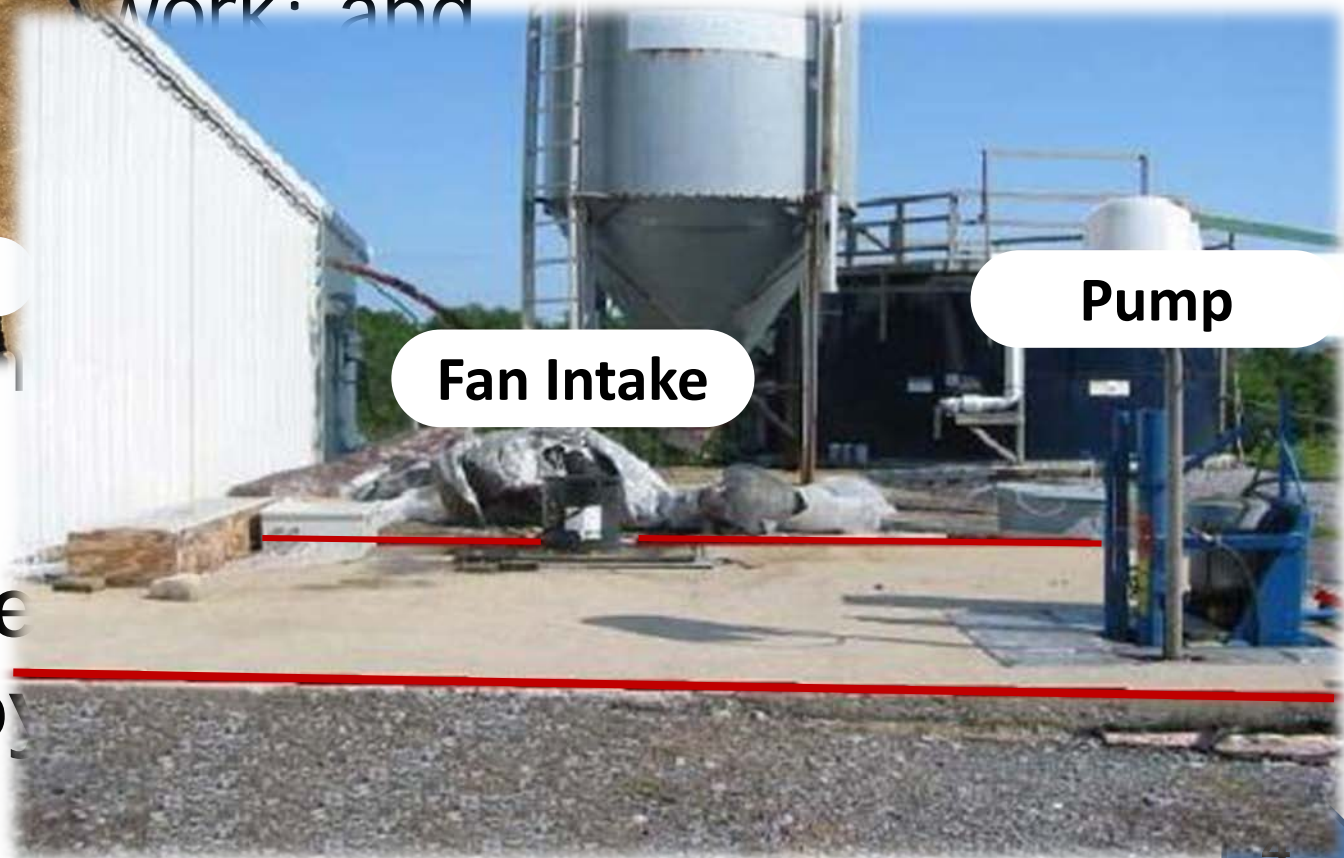

Fan Intake

Pump

**3. Is not de
employ**

Hazards in Confined Space

Manure Storages

1. Toxic and asphyxiating gases

Hydrogen Sulfide

Carbon Dioxide

Ammonia

2. Oxygen deficient atmosphere

3. Explosive gases

Methane

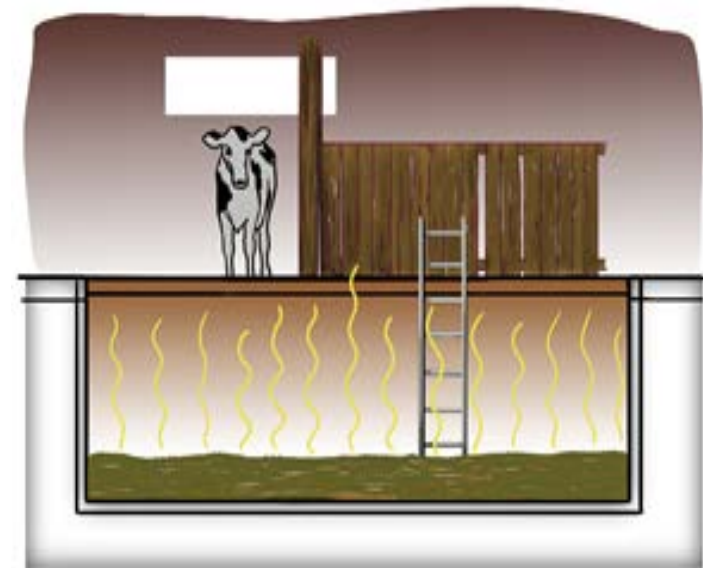

Acceptable Limits for Exposure to Manure Gases

Manure Gas	OSHA Permissible Exposure Limit (PEL) (29 CFR 1910.1000, OSHA, 1995)
Hydrogen Sulfide (H ₂ S)	10 ppm ¹
Ammonia (NH ₃)	50 ppm
Carbon Dioxide (CO ₂)	5,000 ppm
	Lower Explosion Limit (LEL, NIOSH, 2000)
Methane (CH ₄)	5% by volume

¹ A Time-Weighted Average value: work over 8 hours period.

The Problem

- Fatality rate manure pit entry more than doubled between 1975-84 and 1995-2004
- Multiple fatalities are common; often relatives & friends
- Exposure to entry risk becoming more prevalent

Prior Work by PSU Research Team

- Protocols Validated for Computational Fluid Dynamics Simulation (CFD) of **gas concentration reduction** and **oxygen replenishment** during ventilation for selected range of manure pits with:
 - solid* covers
 - totally slotted* covers
 - partially slotted* covers
- Results published in 5 refereed journal articles

Prior Work

- Published and gained consensus approval of the international engineering safety standard, *ANSI/ASABE S607*,

“Ventilating Manure Pits to Reduce Entry Risk”

- ANSI/ASABE S607. 2010. Ventilating confined-space manure storages to reduce entry risk. American Society of Agricultural Engineers. St. Joseph, MI

www.asabe.org

Limitations of Prior Work

1. An estimated 10,000 to 17,000 (approximately 25 to 35 %) of manure tanks in the U.S. fall outside the scope of the current S607 standard.
2. Designers require a **cost effective, user-friendly** Computational Fluid Dynamics (CFD) ventilation simulation process to custom design ventilation systems for particular circumstances.

What is the Online Tool?

1. A **user-friendly, cost-effective** online, web-based computer simulation program for custom designing manure pit ventilation systems
 - Simulates ventilation of stand-alone manure pits
 - Simulates ventilation of manure pits located beneath tunnel-, cross-, or naturally ventilated barns

What is the Online Tool?

2. Combination of SolidWorks, a CAD software package and SolidWorks CFD add-on, SolidWorksFlowSimulation (SWFS), to:

- **develop 3D Computer Aided Design (CAD) models of the manure storages and barns**
- **simulate the time-dependent concentration decay of H_2S , NH_3 , CH_4 and CO_2 gas from ventilated manure storages**

What is the Online Tool?

3. **User friendly interface** for developing the CAD model of the barn, pit, and ventilation system
4. **User friendly interface** for accessing the simulated contaminant gas decay curves, oxygen replenishment curves, and real-time cut plots of gas concentrations in the manure pit and barn.

Cost Effectiveness of Online Tool

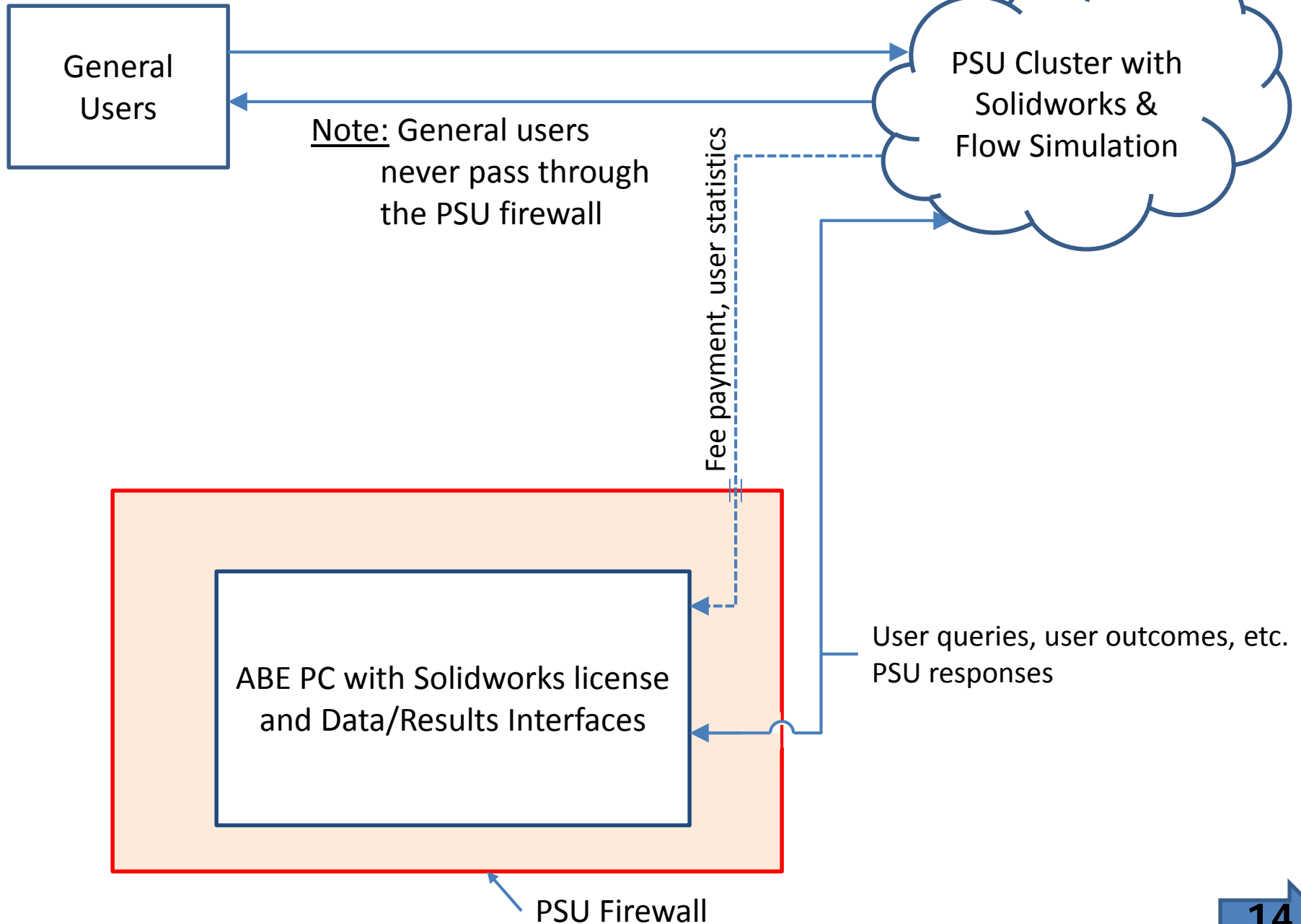

Online Ventilation Design Tool

- Makes it possible to quickly configure many combinations of common pit shapes and features:

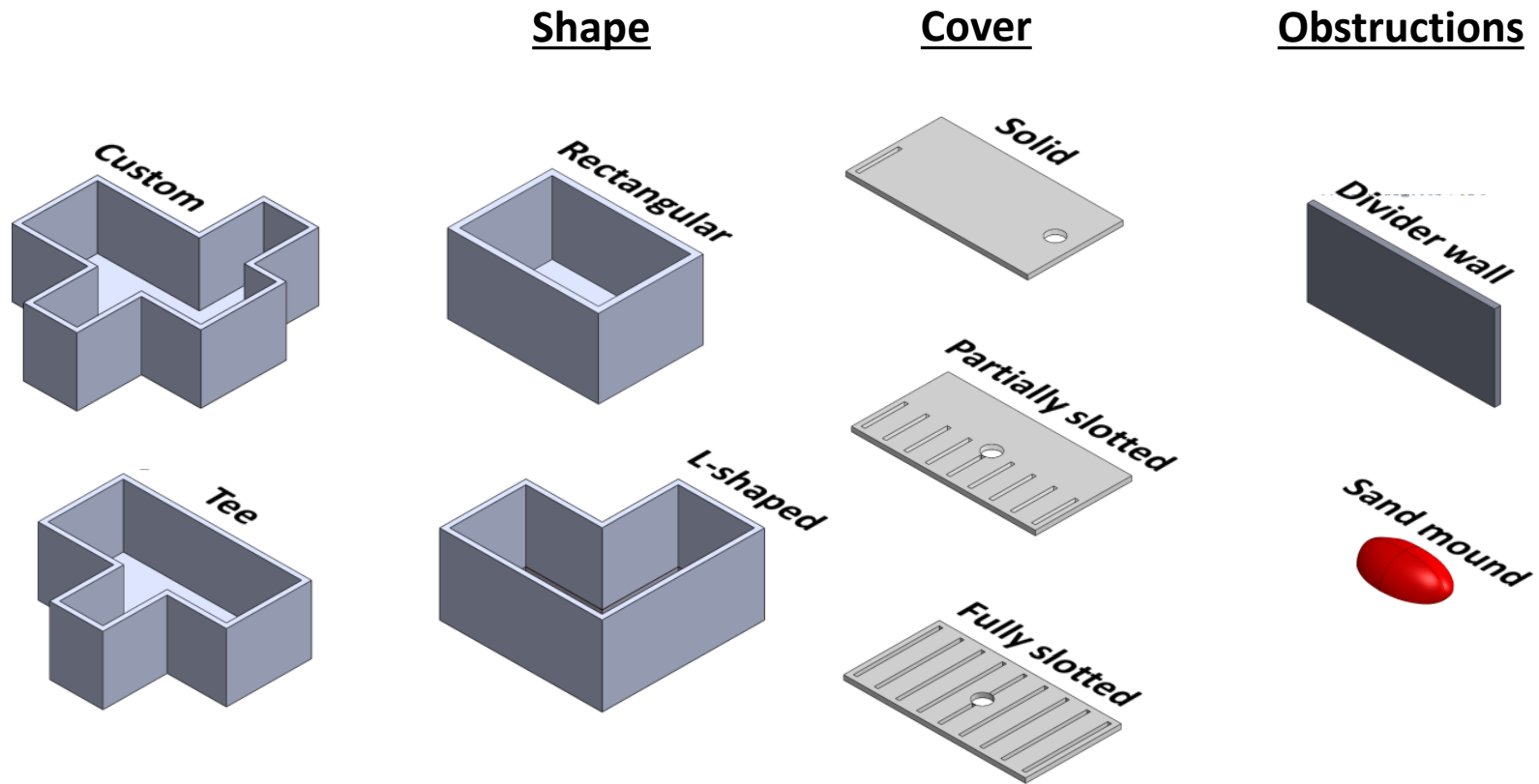

Online Ventilation Design Tool

- We also need to consider the airflow from the ventilated barn above the pit

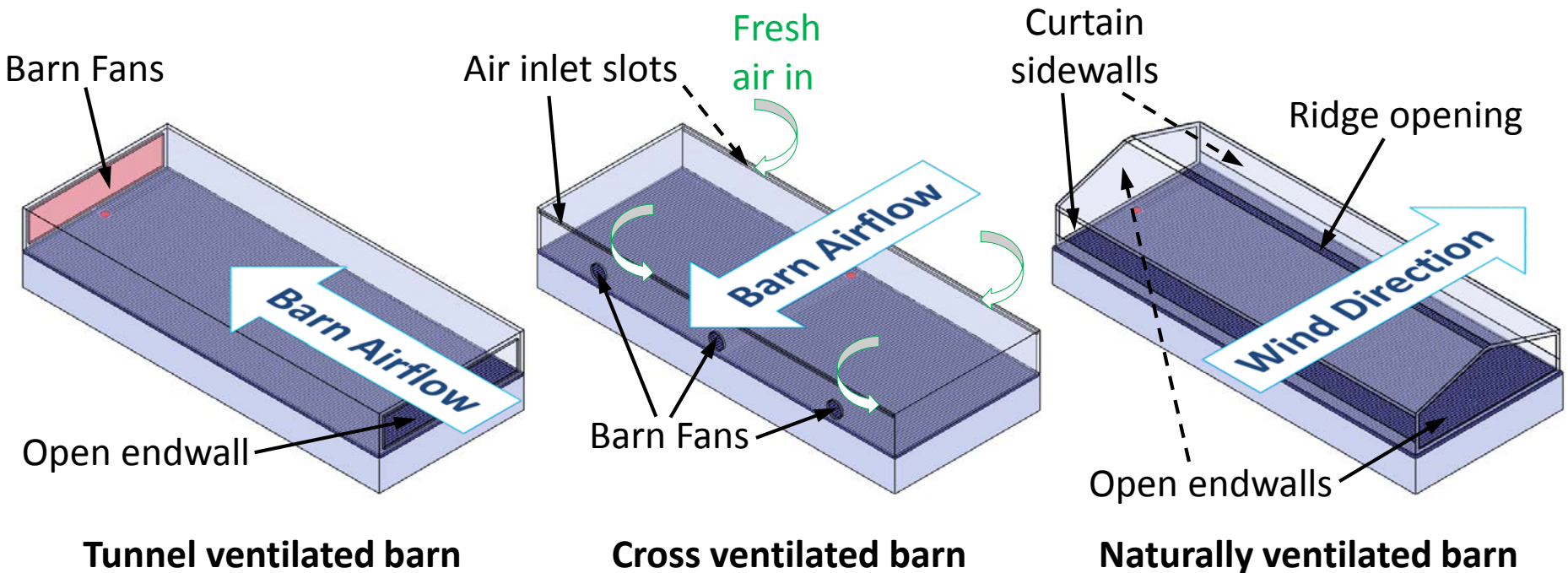

Optional Pit Features

Multiple Outlets

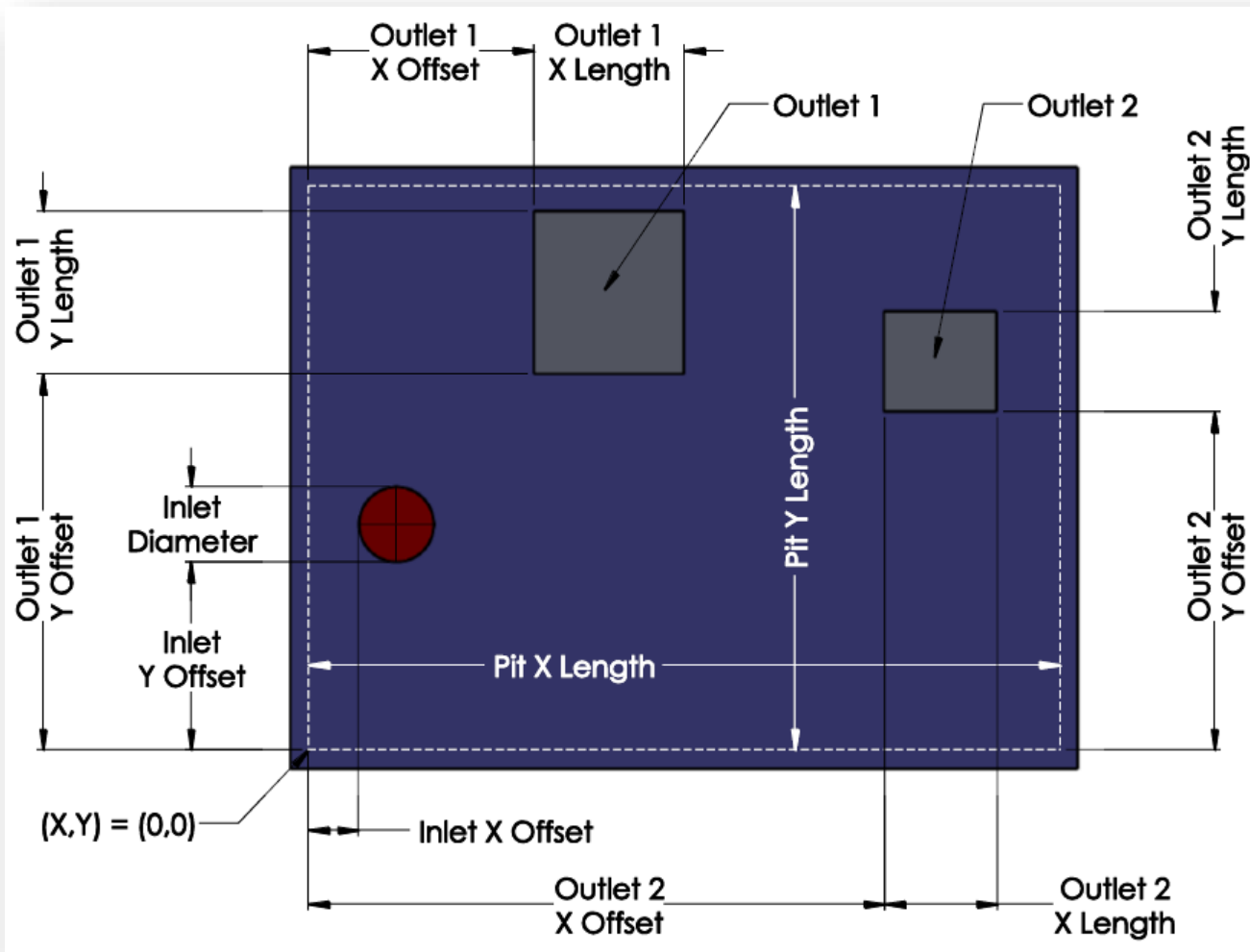

Slotted Flooring

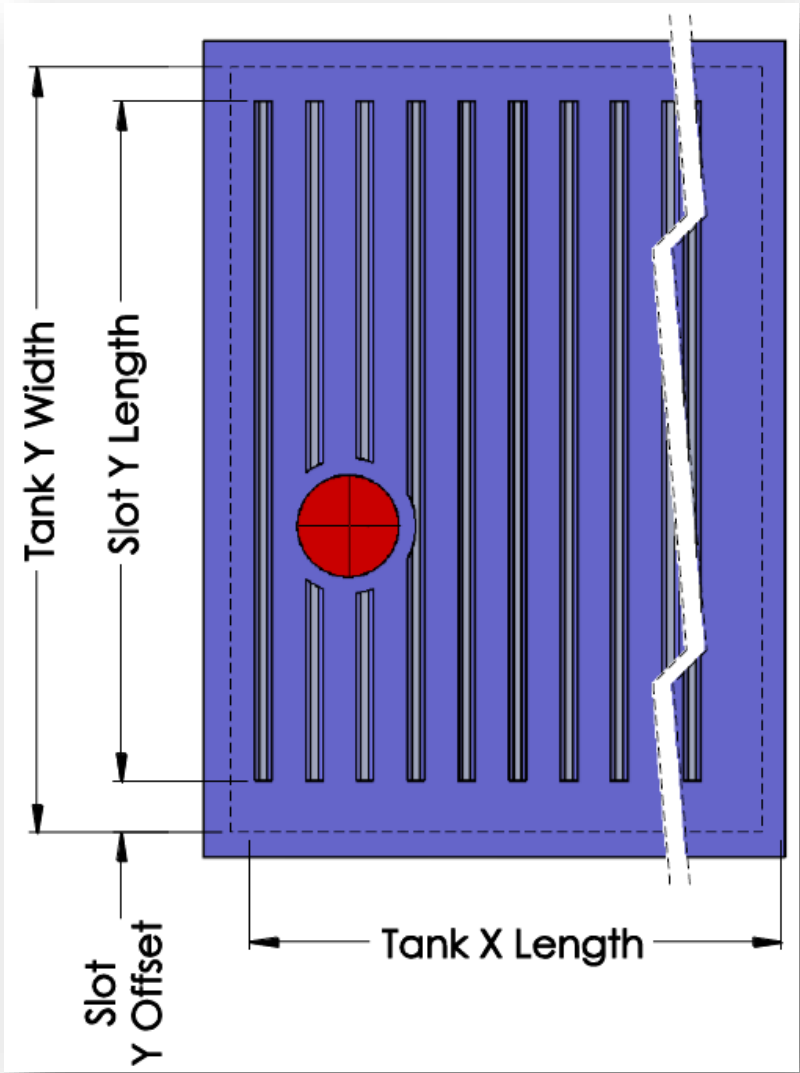

Divider Walls

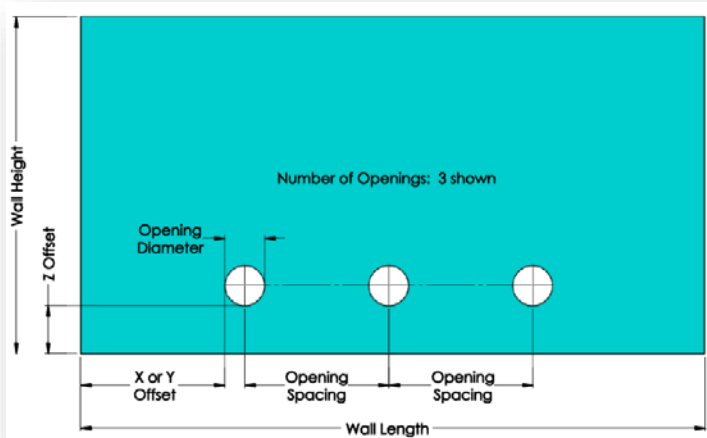
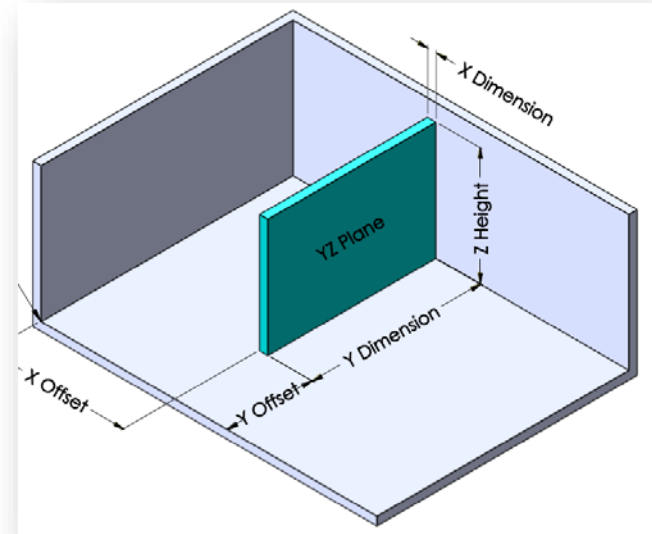
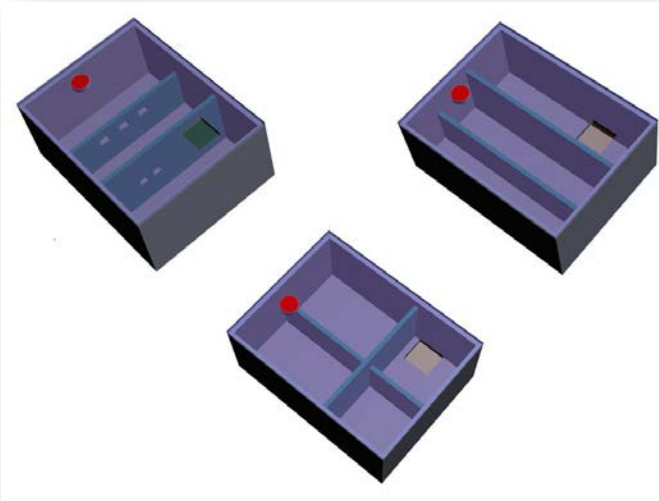

Pumpout Annexes

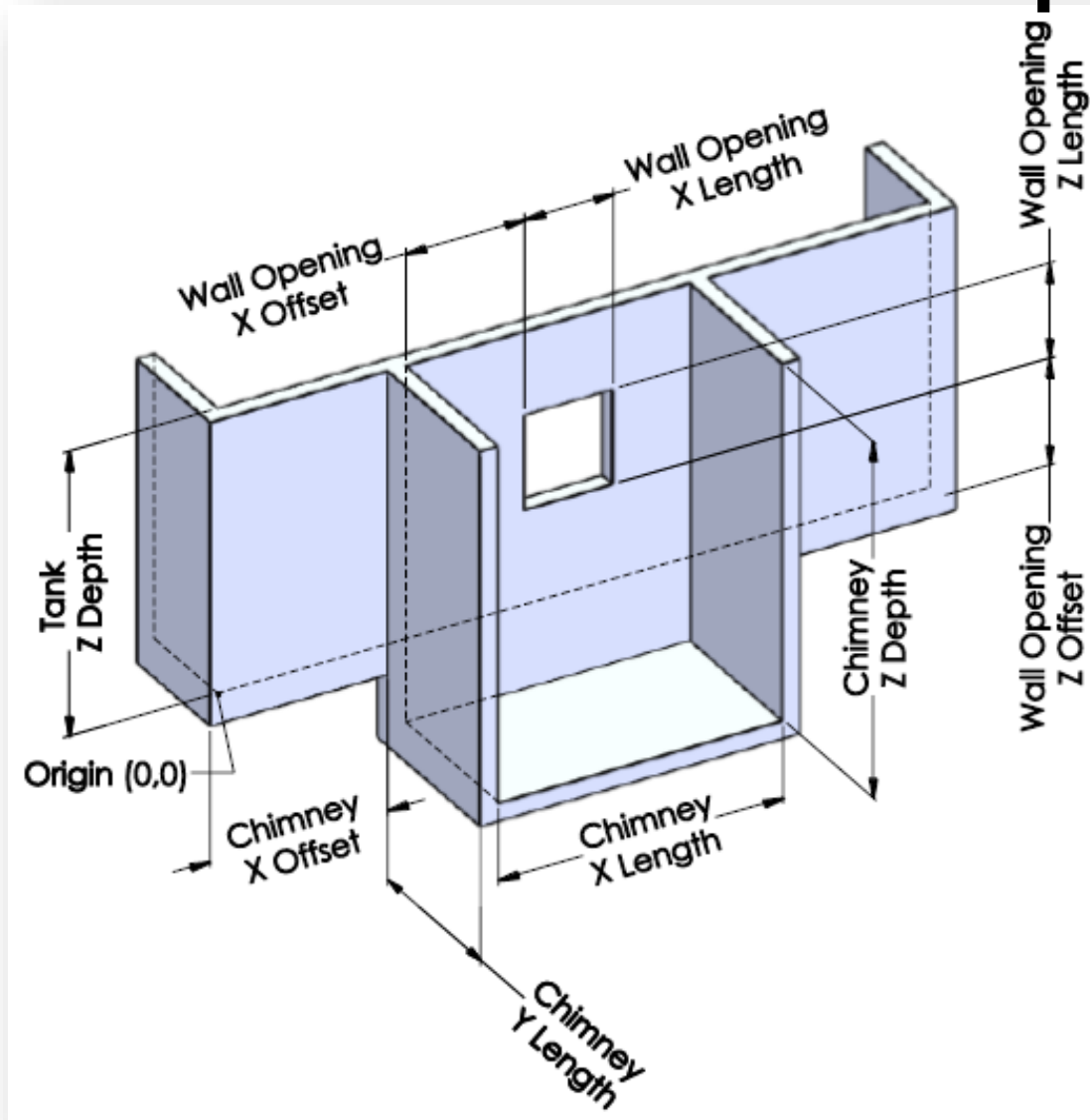

Obstructions

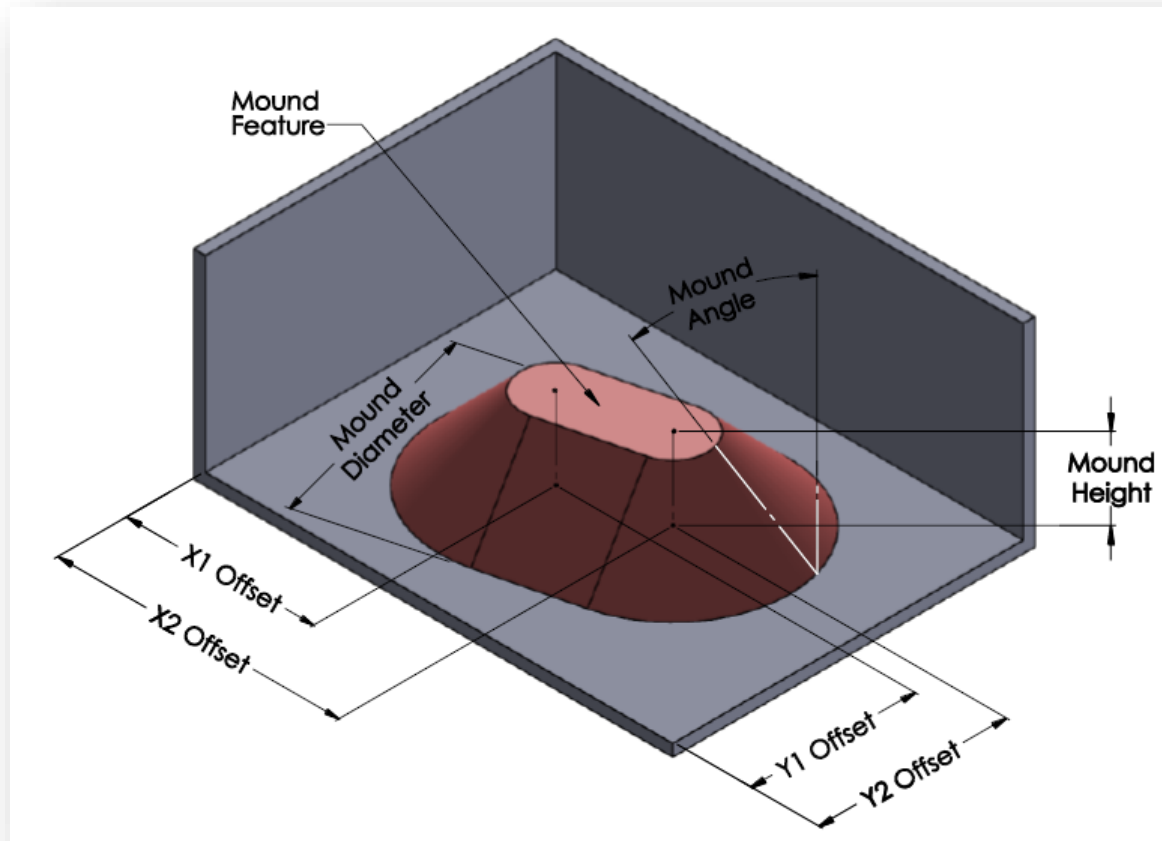

Pit Fan Outlet Elbow

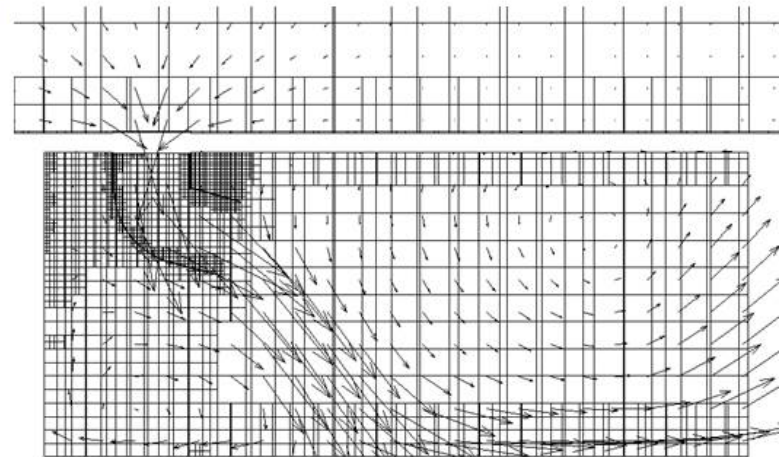
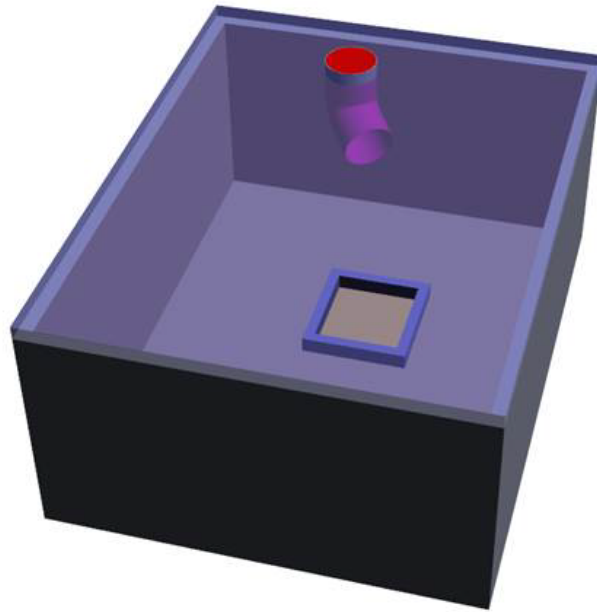
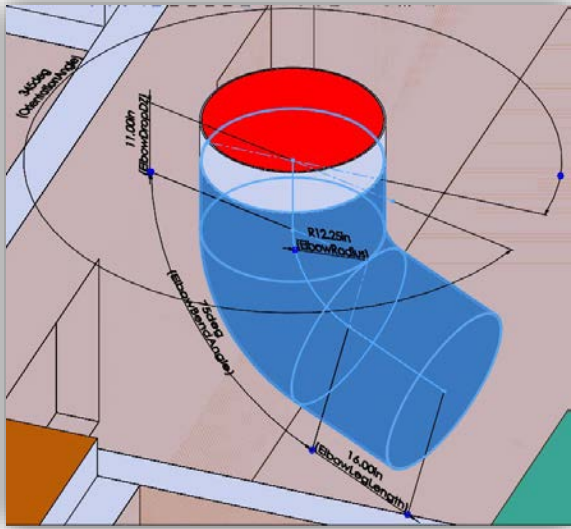

Barn Features

Tunnel Ventilated Barn

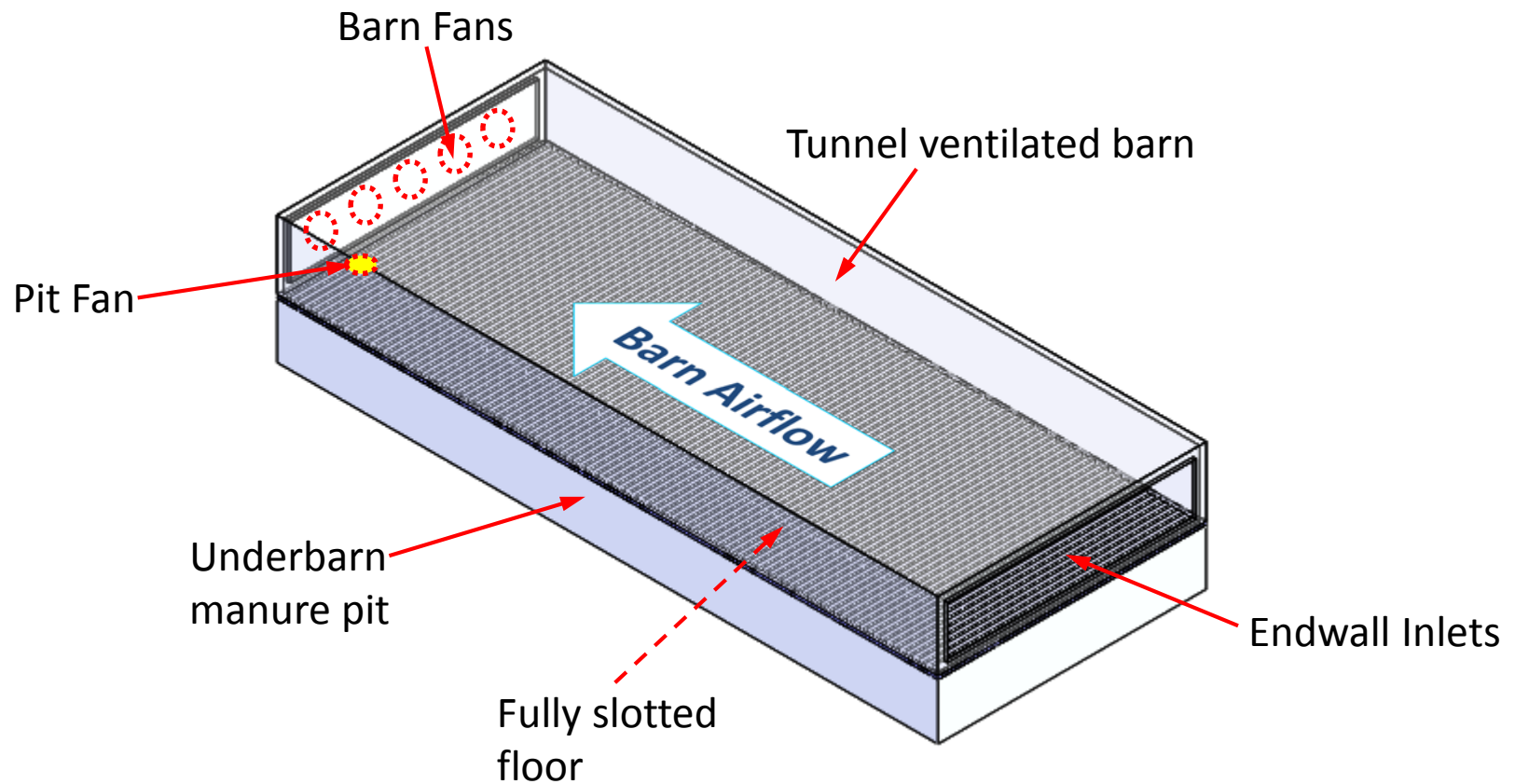

Cross Ventilated Barn

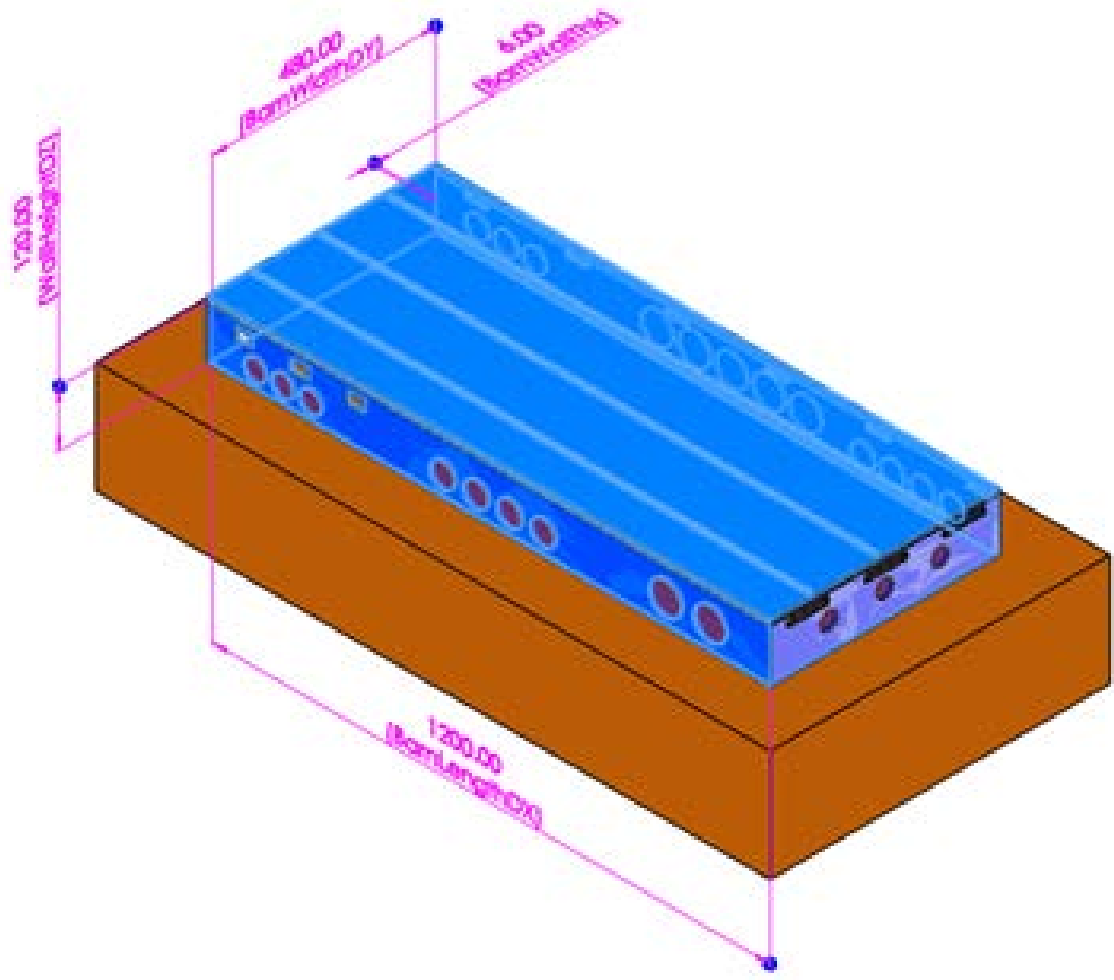

Cross-Ventilated Barn

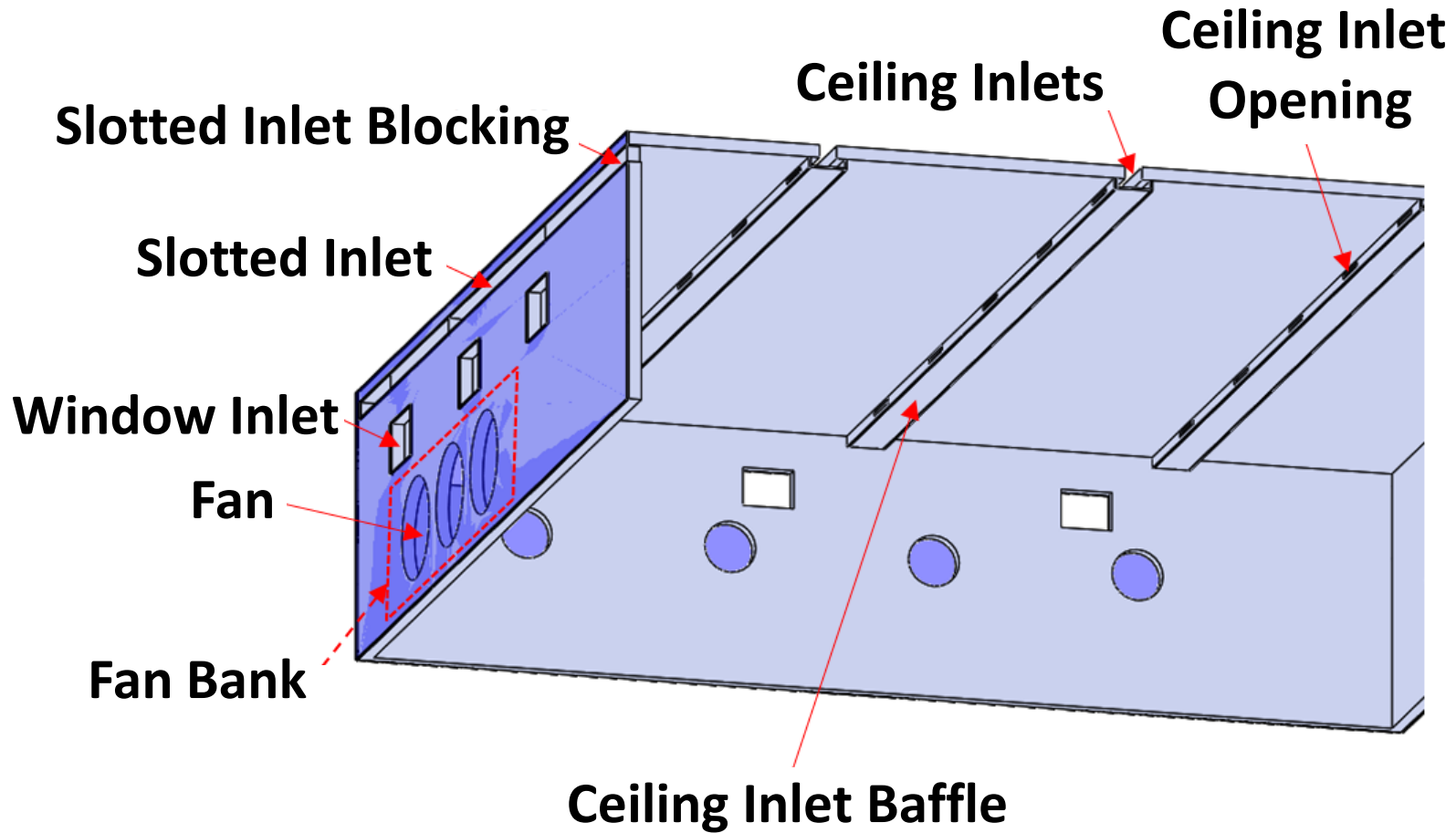

Naturally-Ventilated Barn

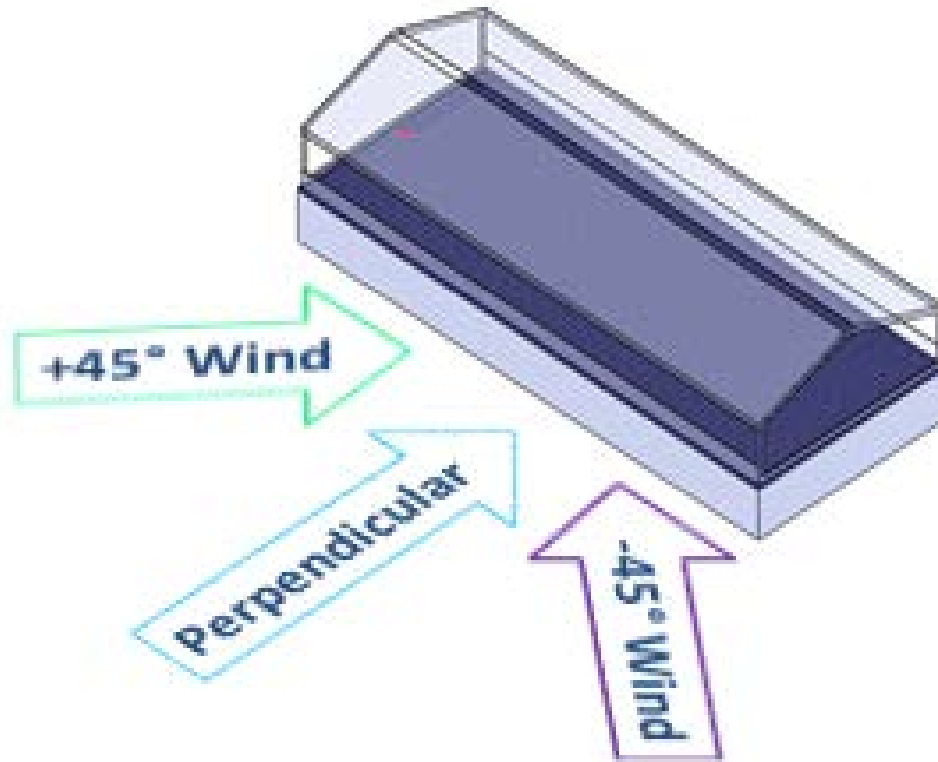

Ridge Vent and Sidewall Openings

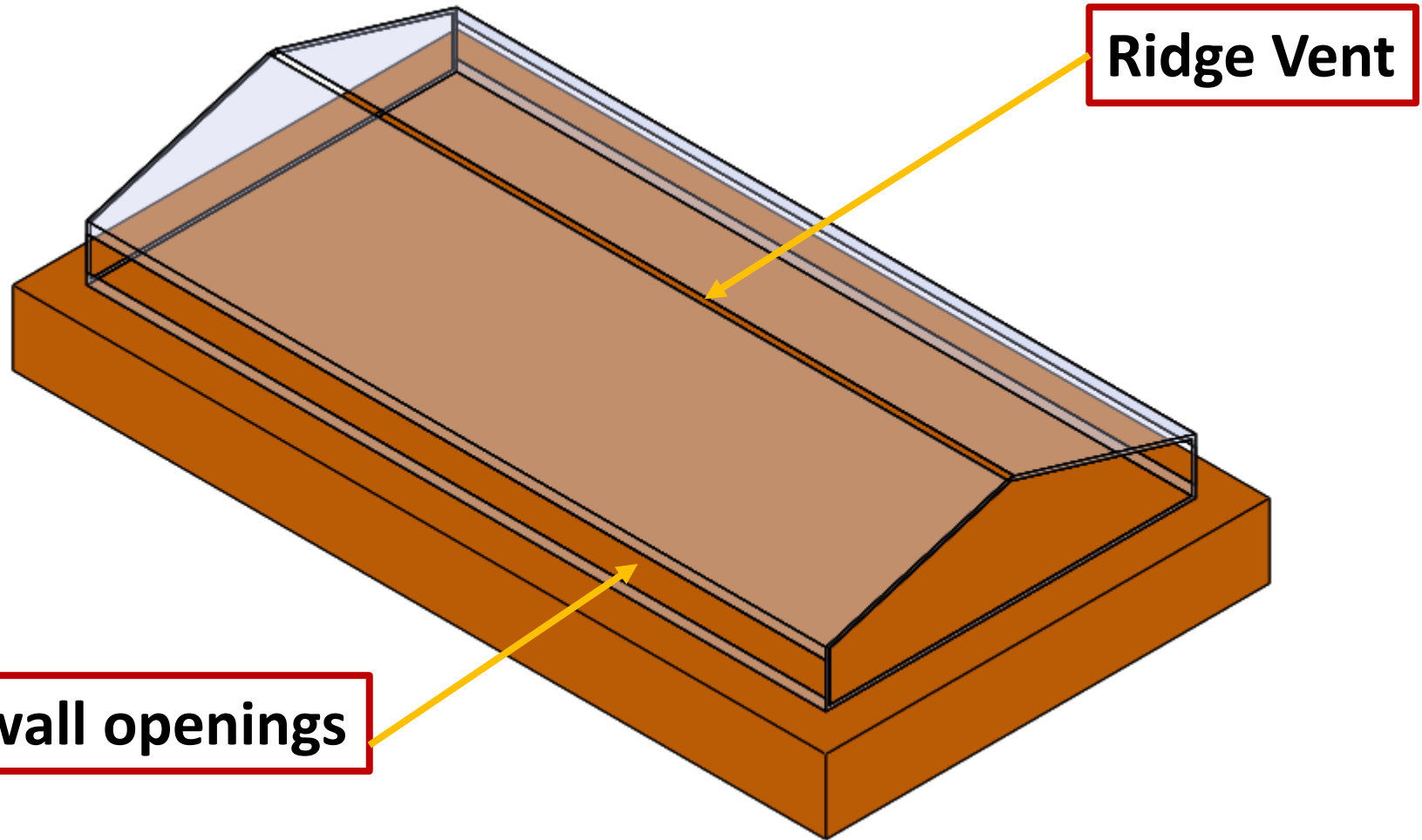

Endwall Sheathing

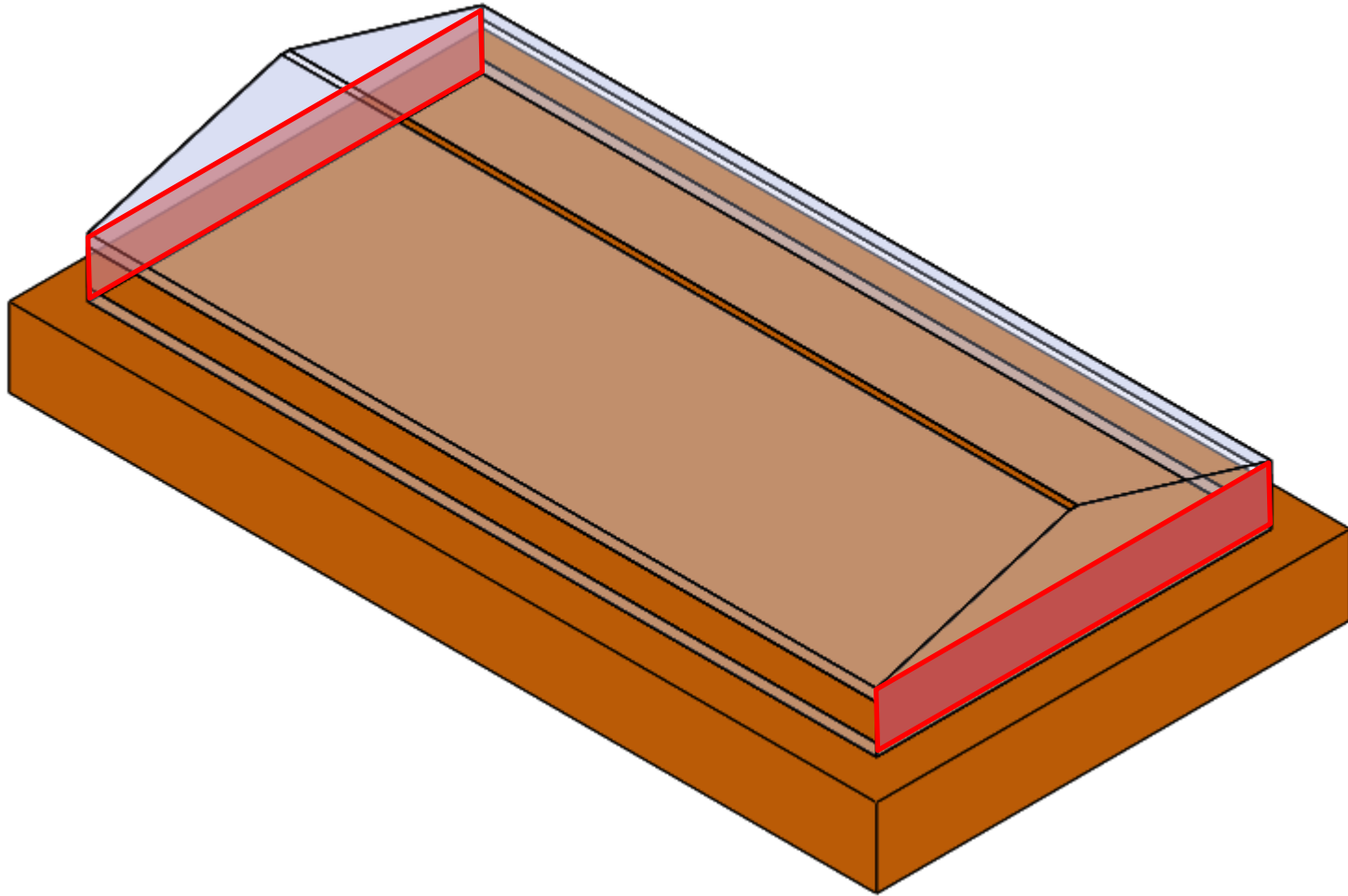

Endwall Doors

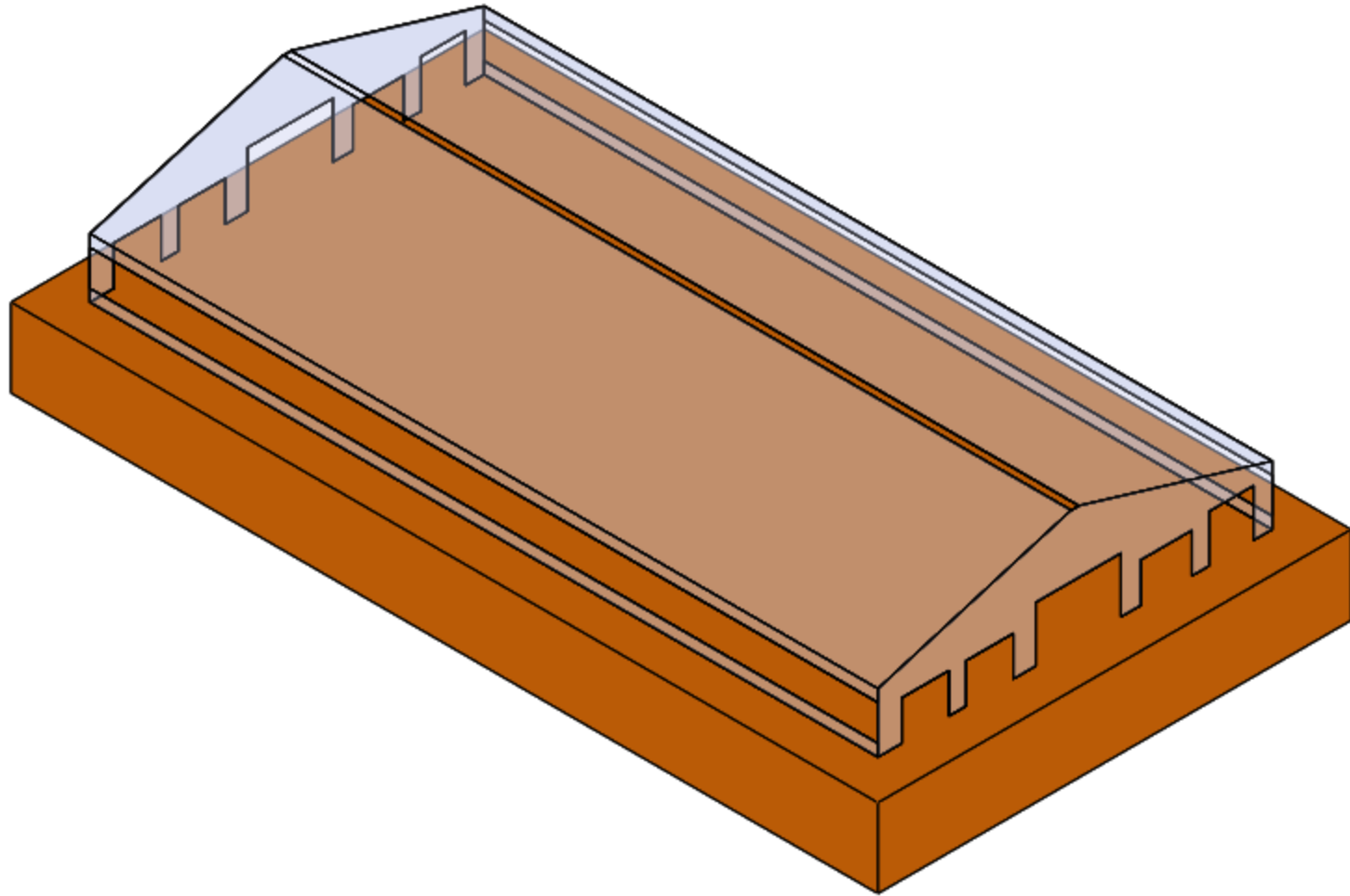

Wind Obstructions

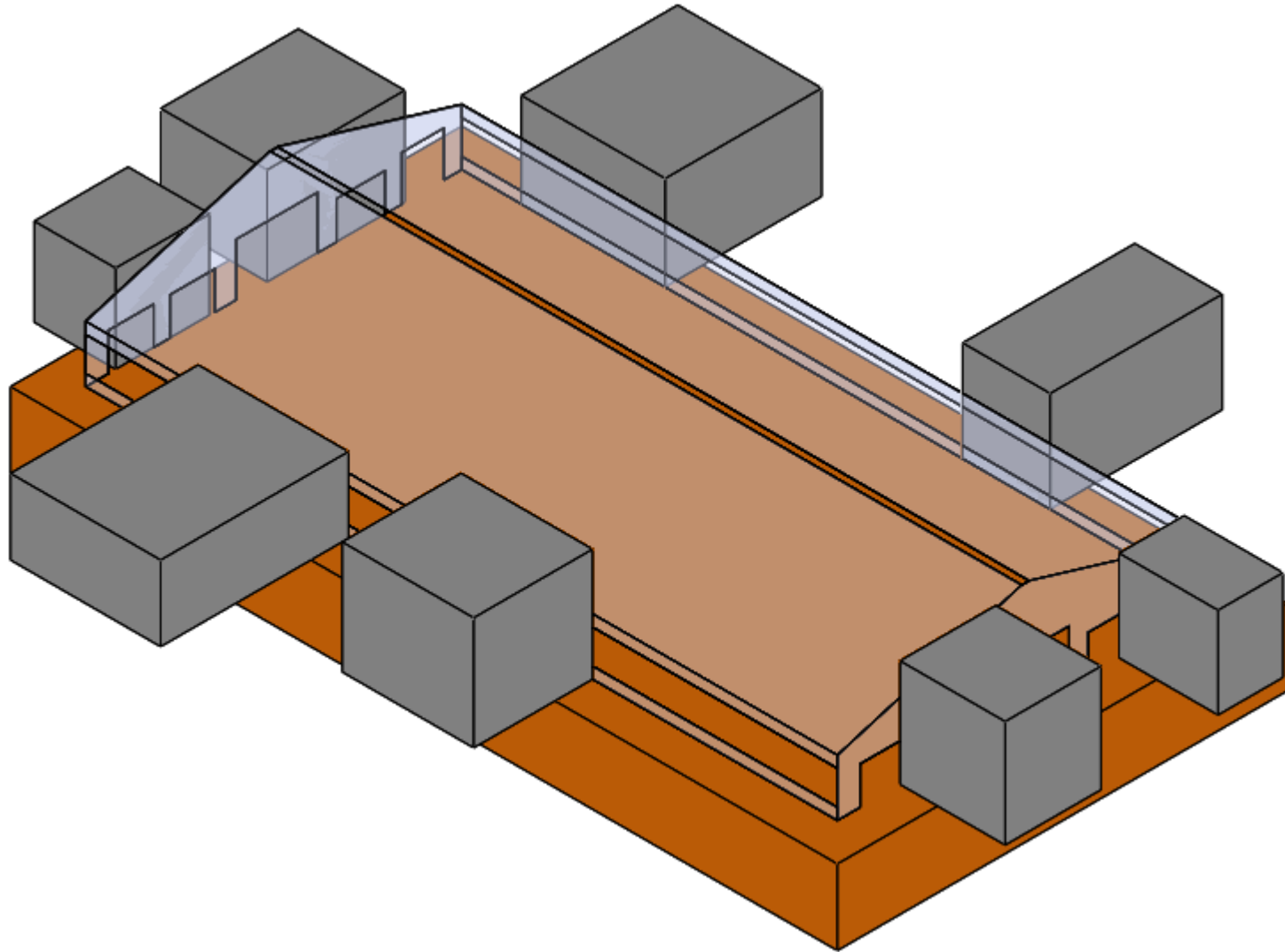

Manure Pit Gas Decay Curve

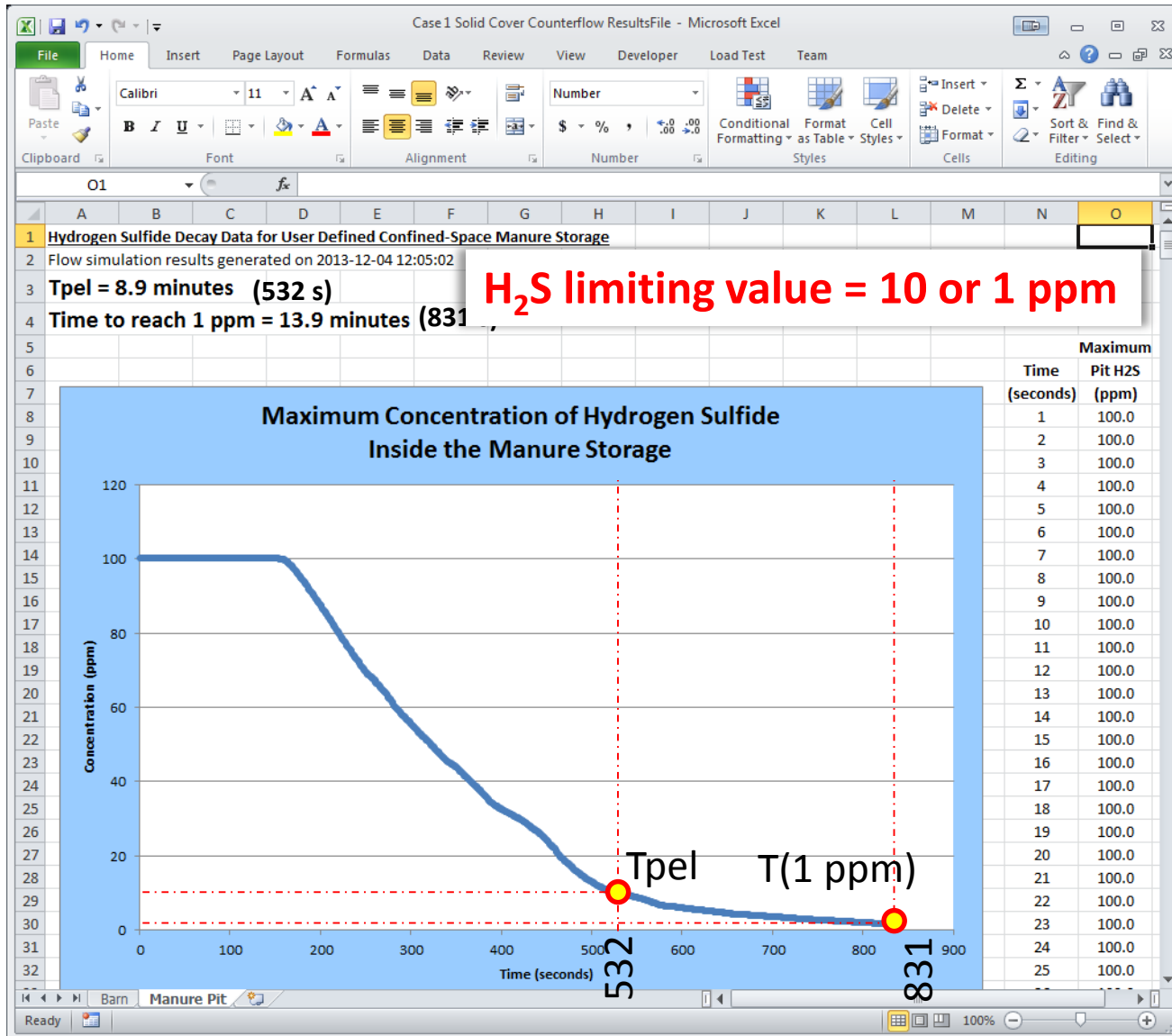

Barn Airspace Gas Decay Curve

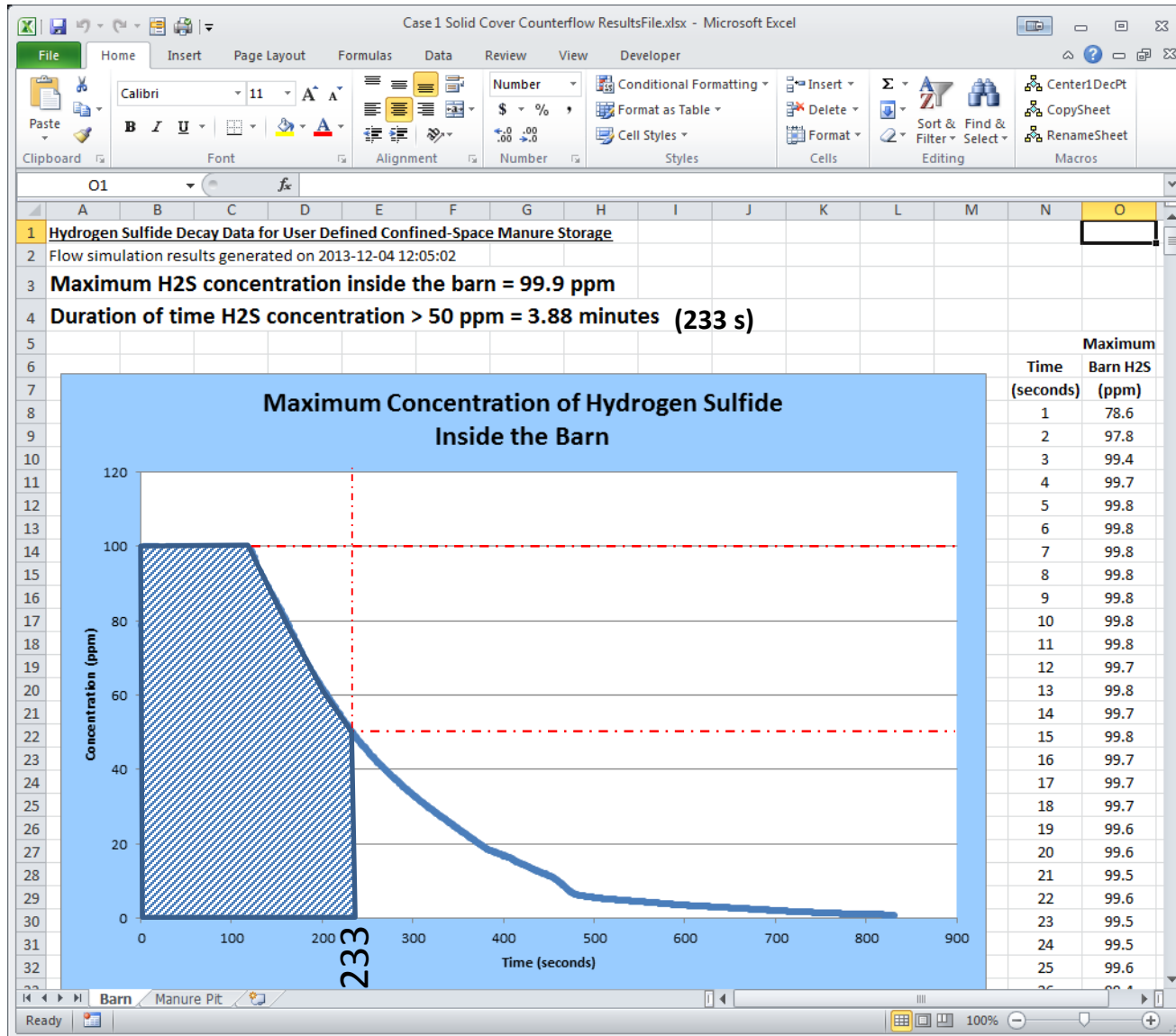

Results for Each Gas in Pit and Barn

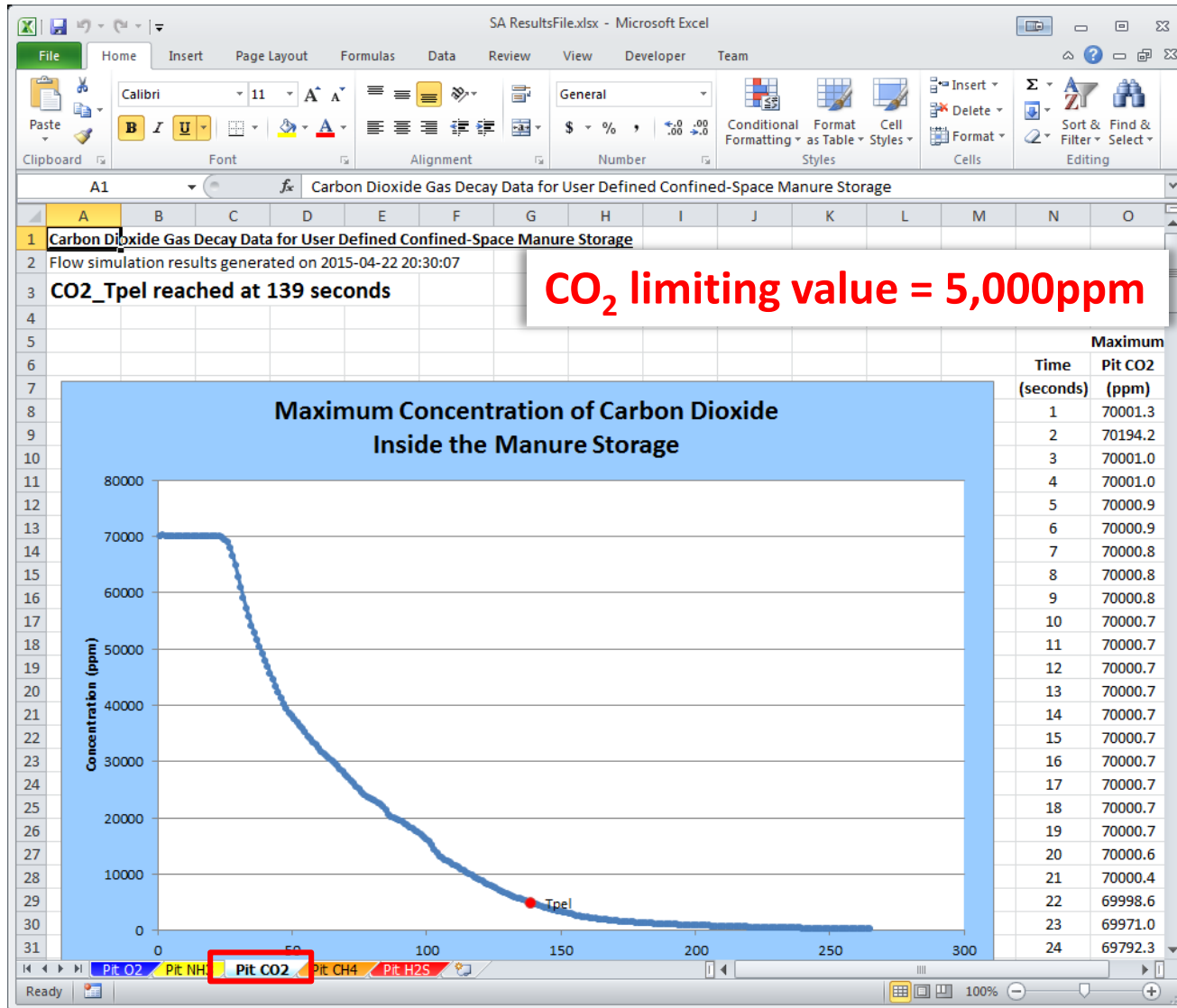

Separate tabs for each gas in the pit and barn

Simulation Results

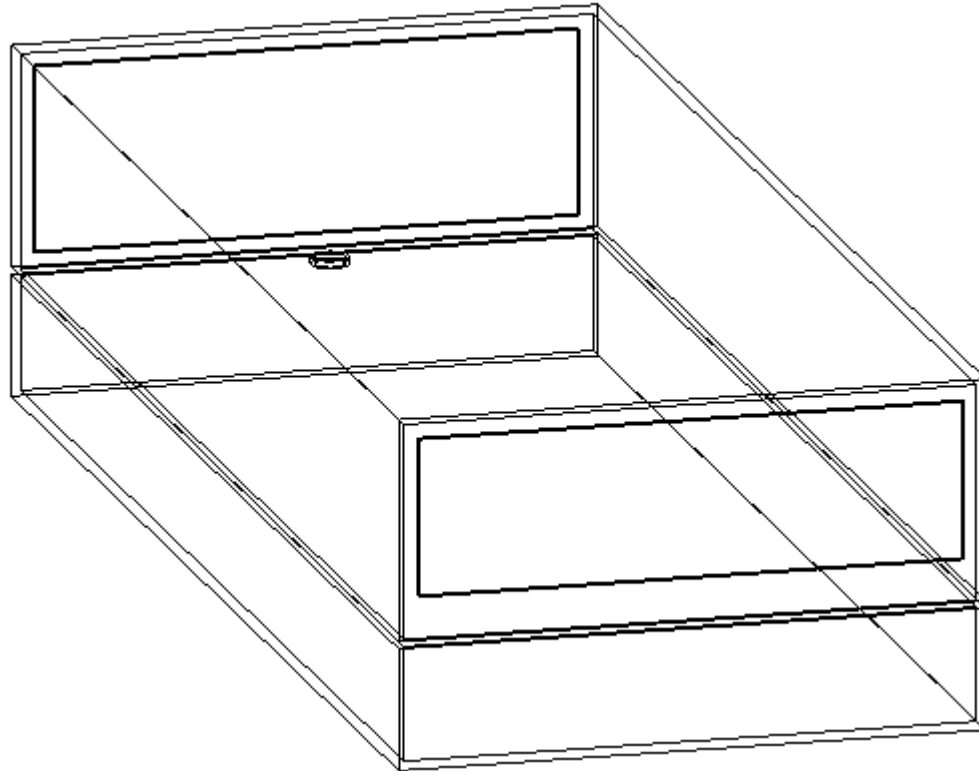

Simulation Results

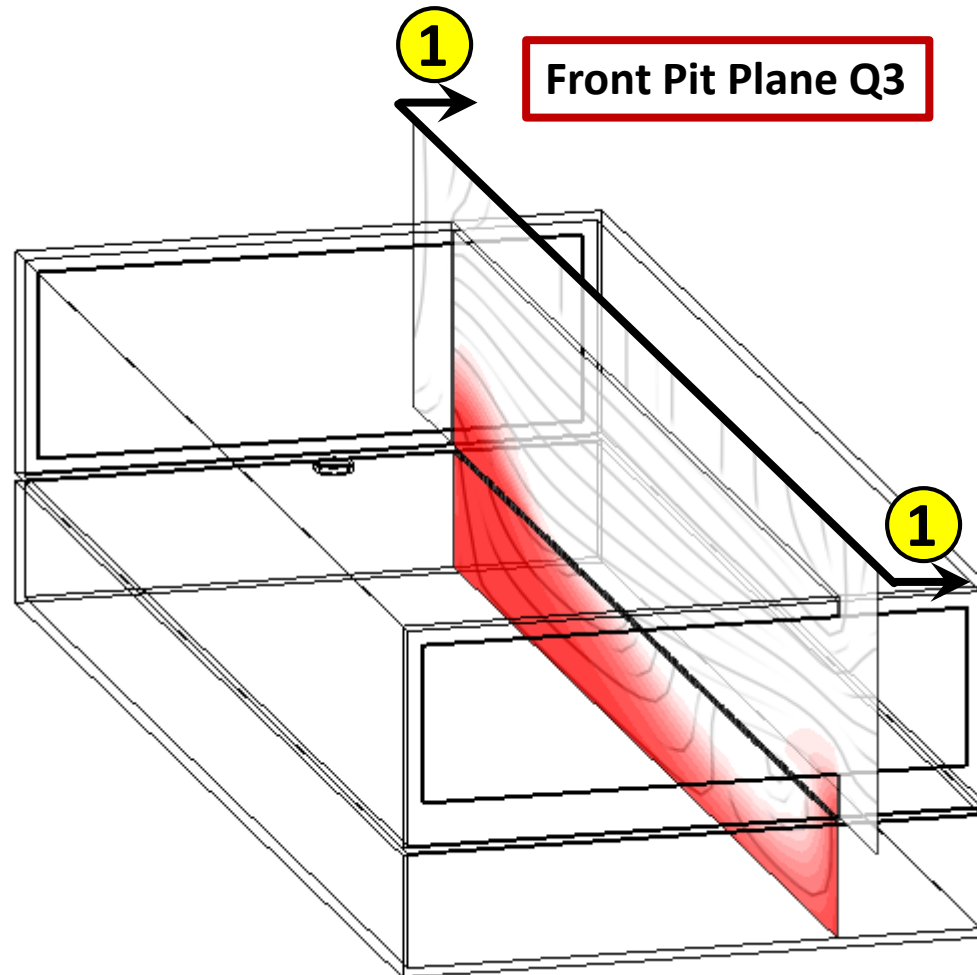

Simulation Results

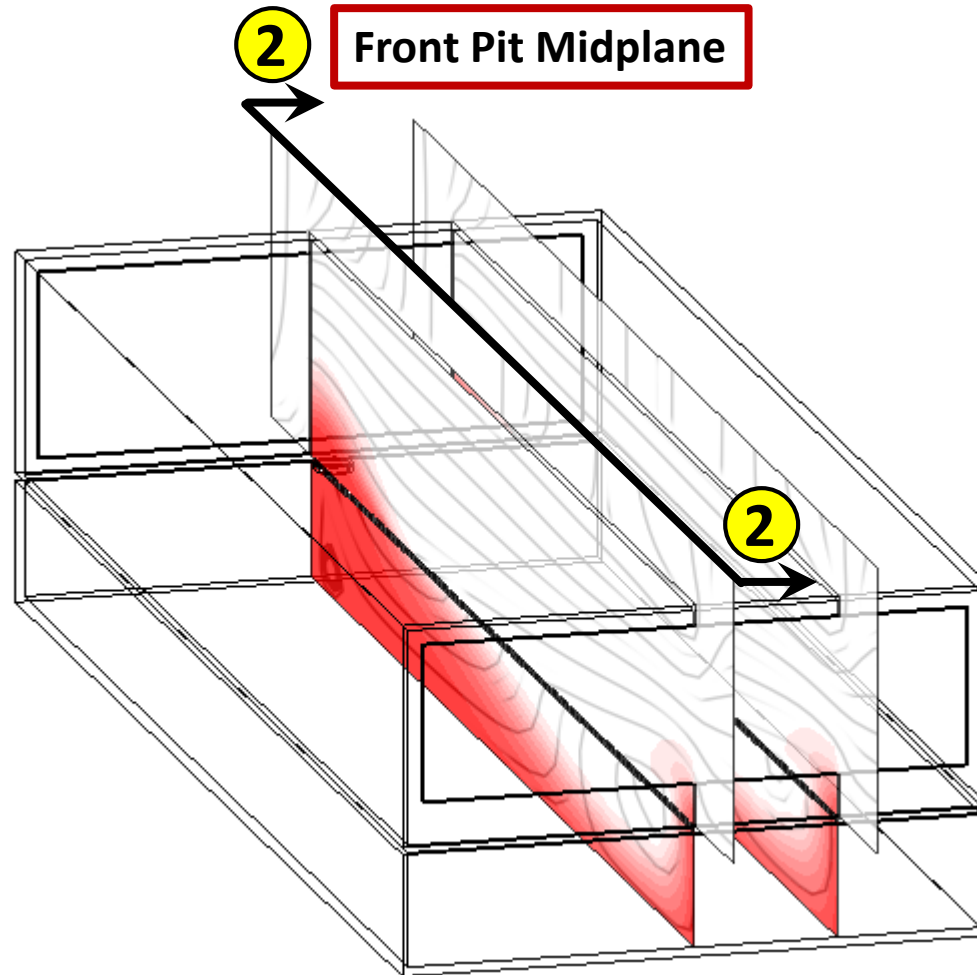

Simulation Results

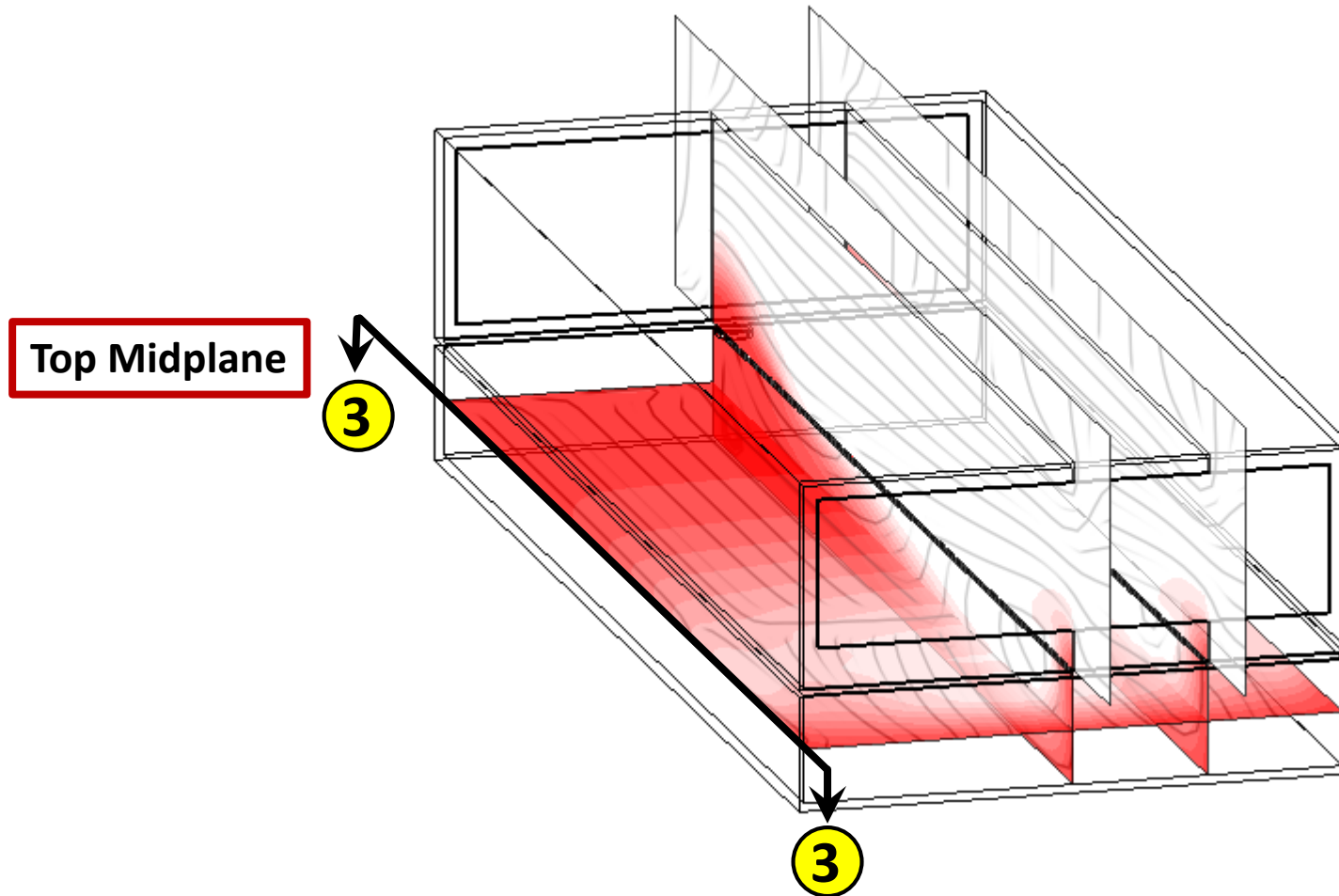

Simulation Results

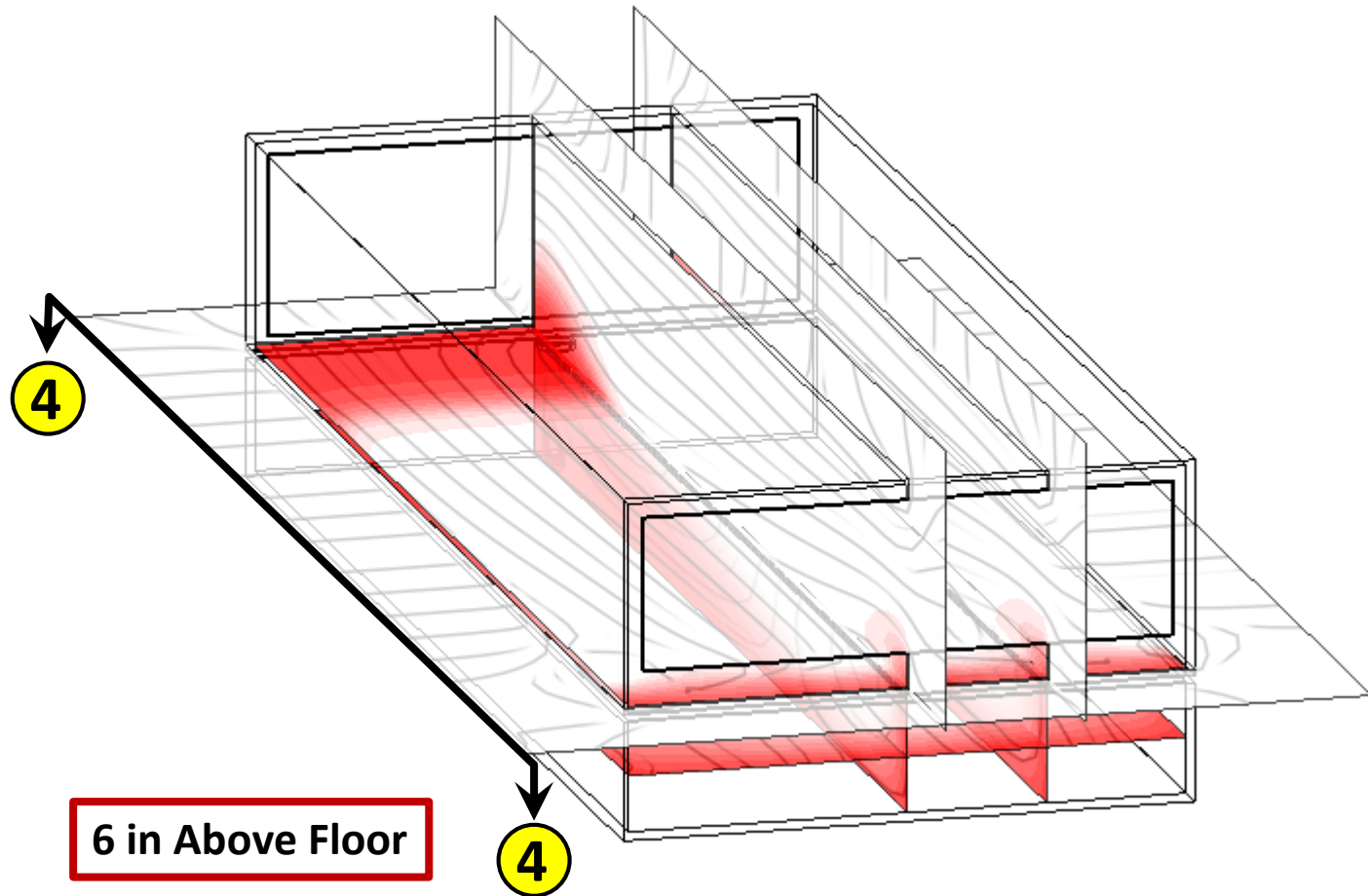

Simulation Results

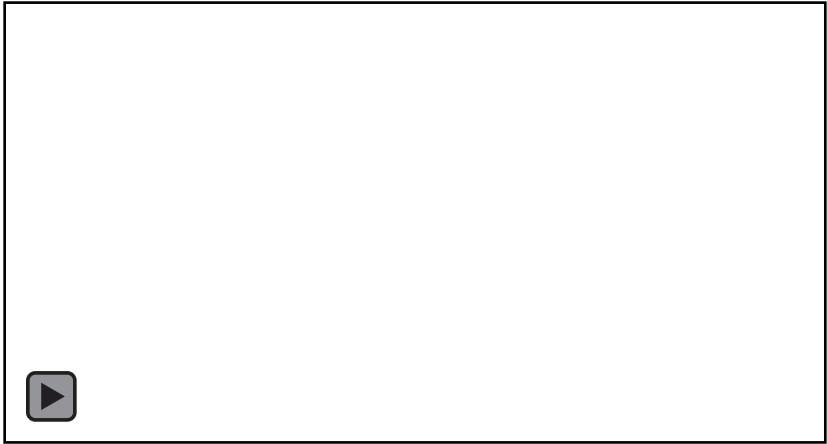
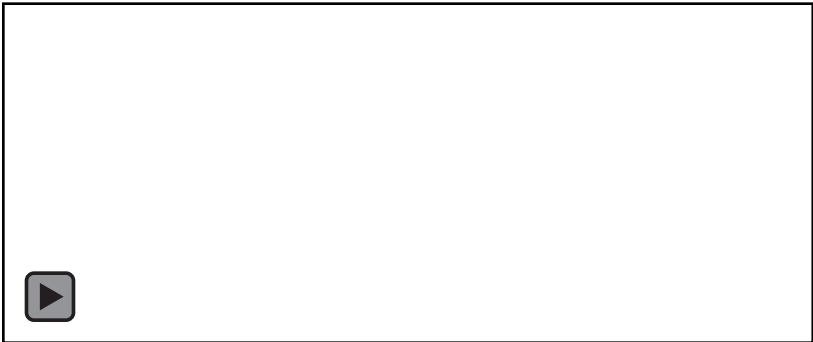
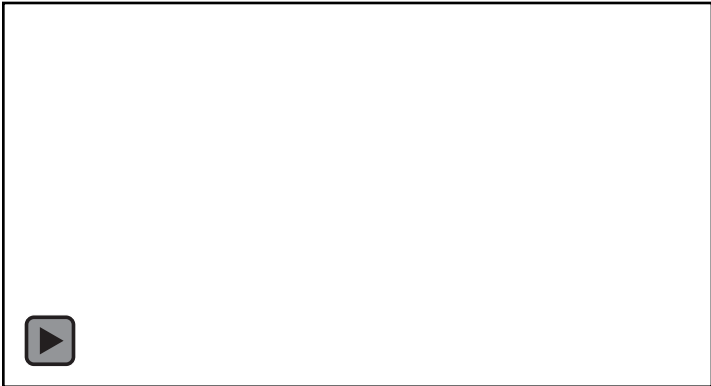
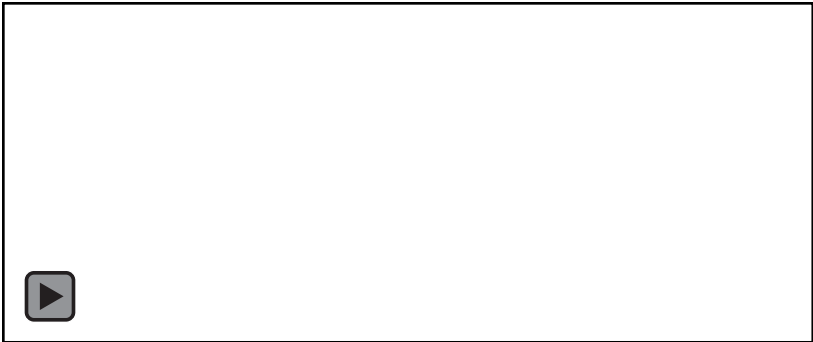
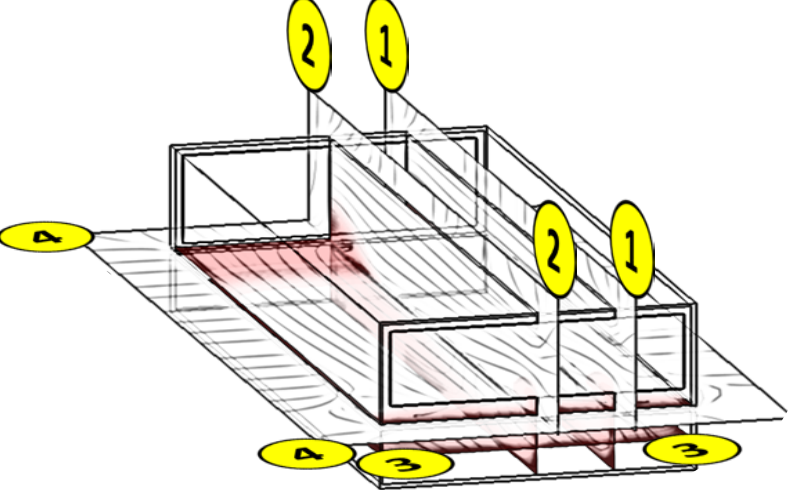

Design Example: Tunnel Ventilated Barn Above Slotted-Covered Manure Pit

- Define the design case
- Create a tunnel ventilated barn above a manure pit data file
- Review the input data
- Solve the case study
- View selected results
- Interpret the results

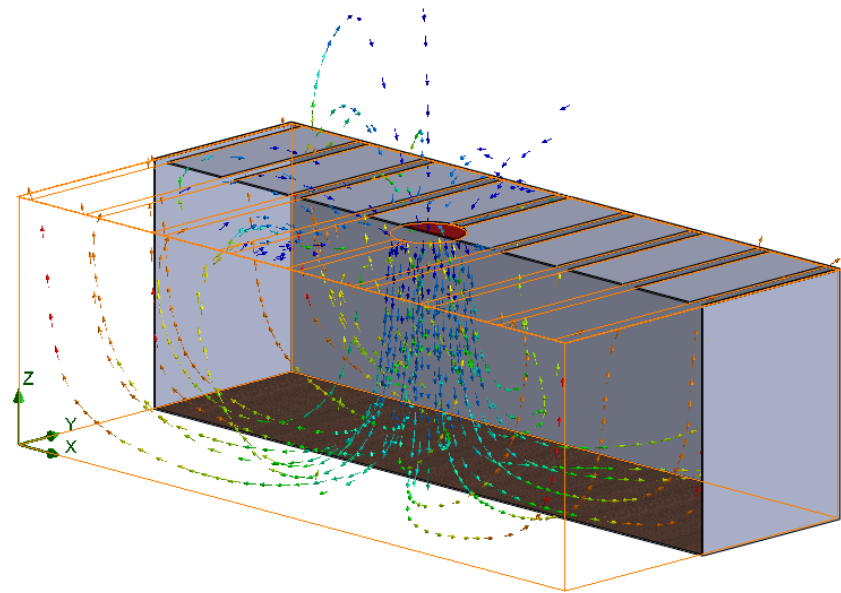

Overview of Tunnel Ventilated Barn above Pit with Slotted Cover

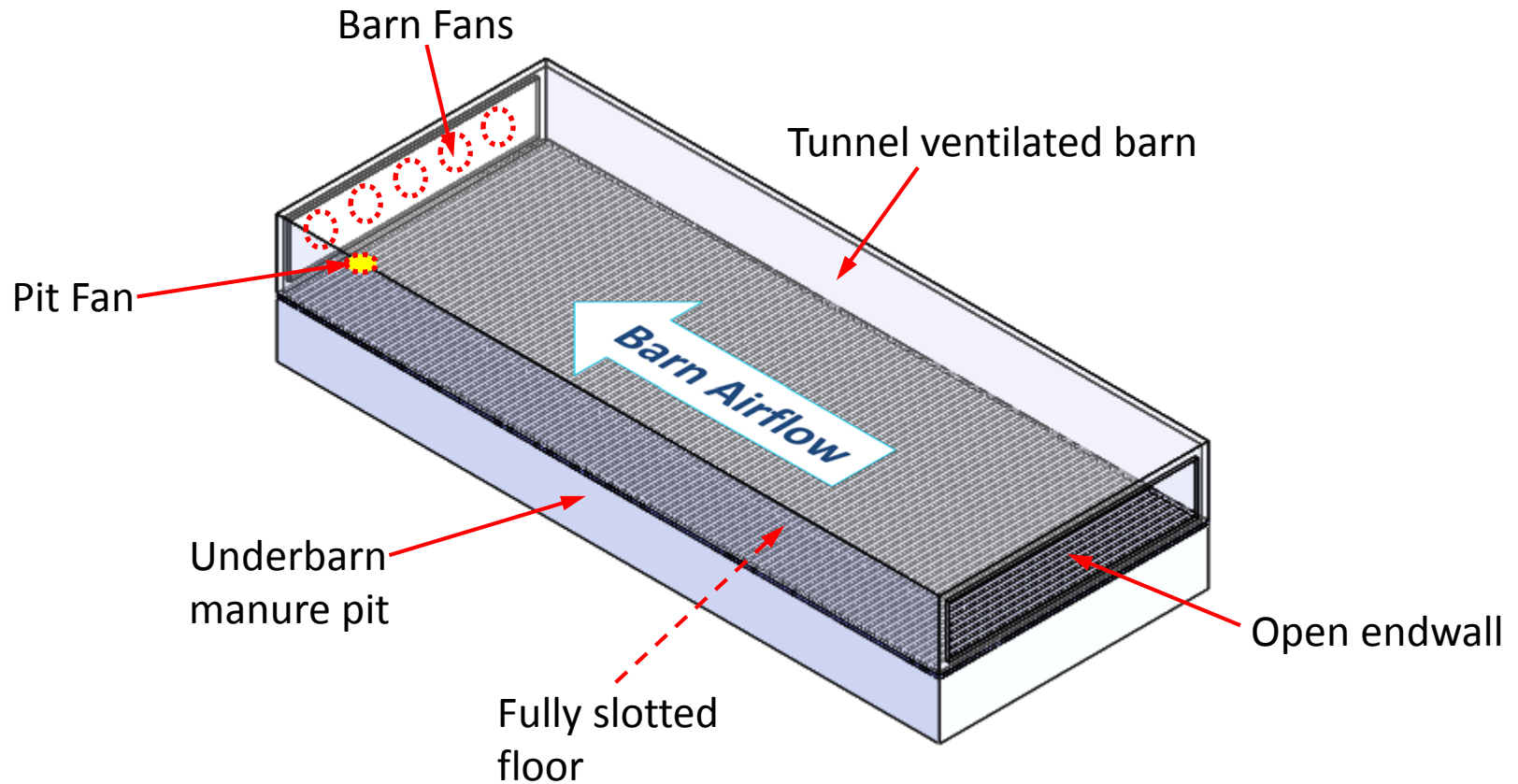

Isometric view of Pit + Barn

Constraints and Assumptions for CFD Simulations

- **Barn Ventilation: Negative pressure system**
- **Pit ventilation: Positive pressure system**
- **Default** initial conditions inside manure pit:
 - Pit is empty, no agitation, no gas generation
 - Initial gas concentrations (**can** be changed by user)
 - $\text{H}_2\text{S} = 100$ ppm
 - $\text{CO}_2 = 700$ ppm
 - $\text{CH}_4 = 15,000$ ppm
 - $\text{NH}_3 = 240$ ppm
 - $\text{O}_2 = 0$ ppm (no oxygen present)

Constraints and Assumptions for CFD Simulations

- **Default** manure pit configuration:
 - Pit fan draws air from mix of fresh and contaminated gas evacuated from pit (User can select ducted fresh air inlet if appropriate)
 - No obstructions in pit (can add)
 - No divider walls (can add)
 - No pump out annexes (can add)
 - Pit cover is totally slotted (can be changed)
 - Pit fan delivers air in direction perpendicular to pit cover (can change the direction)

Tunnel Ventilated Barn + Pit Design Case

- Barn: Fully slotted 40 ft. x 100 ft. x 10 ft tunnel ventilated (parallel flow) swine finishing barn for 450 finishing pigs
- Barn maximum ventilation rate: 55,000 cfm
- Manure Pit: 40 ft (W) x 100 ft (L) x 8 ft (D) underneath barn
- Manure pit ventilation rate: 9,500 cfm
- Pit fan size & location: 2 ft dia.; in pit cover, offset 3 ft from end wall with barn vent intakes and 20 ft from front sidewall (ventilation air directed downwards)
- Initial pit gas concentrations:

H ₂ S- 120 ppm	CO ₂ - 70,000 ppm
CH ₄ - 85,000 ppm	NH ₃ - 300 ppm
- Pit fan intake air: Mixture of fresh air and exhausted pit gases (recirculation)

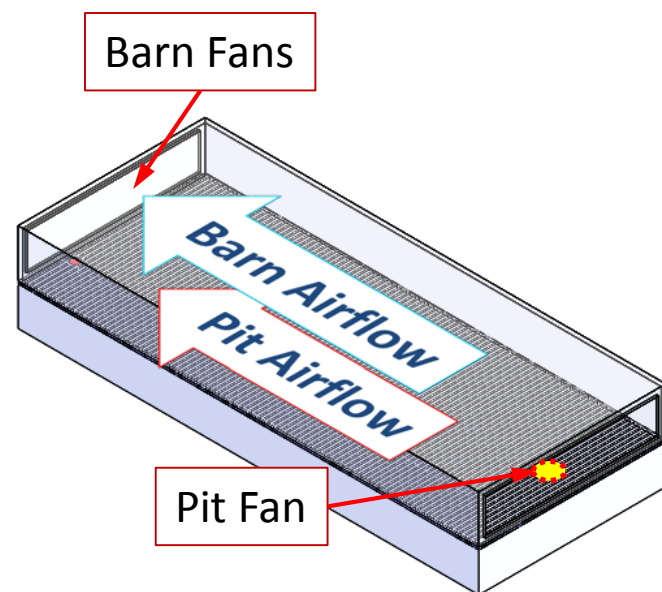

Slotted cover, parallel flow

Next: Demonstration of Online Tool for this Case

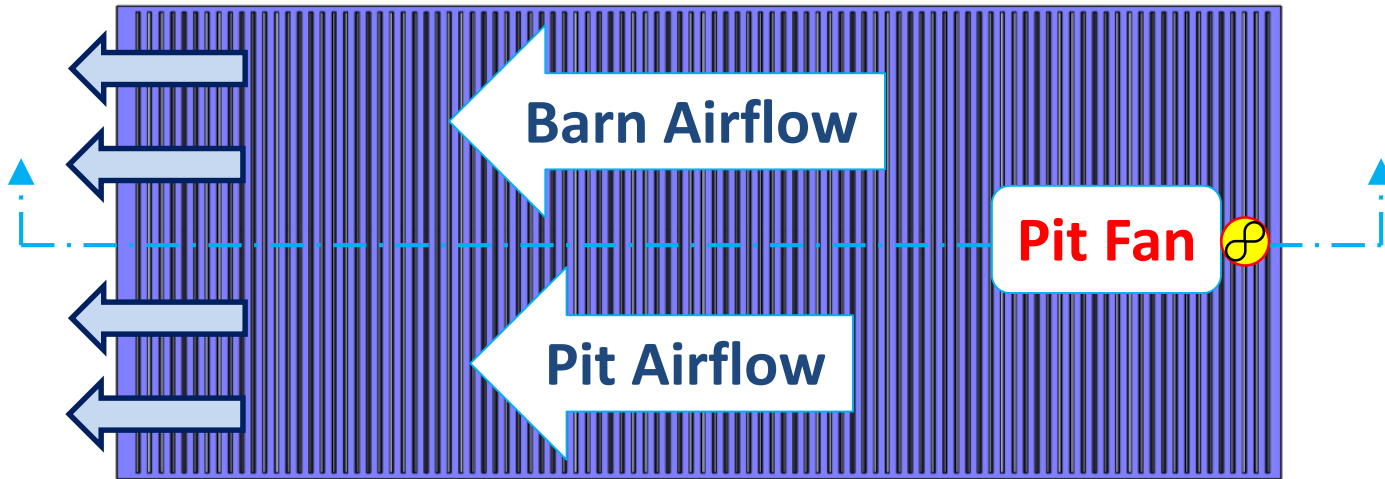

Plan View of Pit + Barn

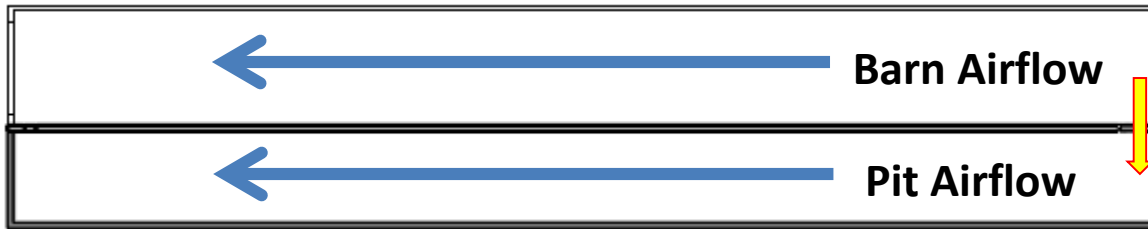

Section View of Pit + Barn

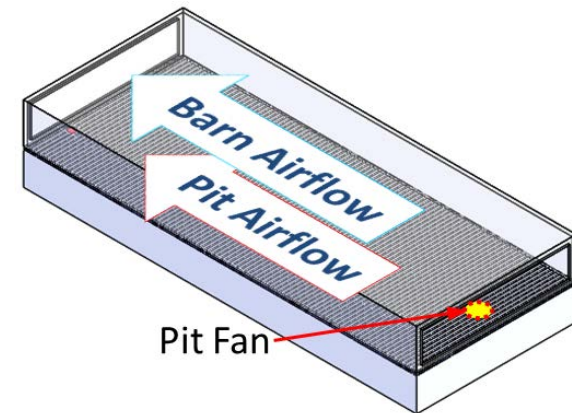

Step 1: Open online tool in web browser.

https://ventdesign.agsafety.psu.edu

PENNSTATE
College of Engineering

Confined-Space Manure Ventilation Design Tool

Welcome to the Penn State College of Engineering Confined-Space Ventilation Design Tool

This is an online tool that manure pit designers and field engineers can use to predict how long a confined-space manure pit will be ventilated before it is safe to enter through the animal housing. The tool also simulates, and can be used to determine whether or not animals need to be evacuated from the barn during pit ventilation.

<http://ventdesign.agsafety.psu.edu>

[Click here for more information about this online tool](#)

[Click here to login](#)

If you do not yet have an account, apply for one by clicking the link below.

[Click here to apply](#)

Step 2: Log in to online tool.

https://www.engr.psu.edu

https://ventdesign.agsafety.psu.edu?ReturnUrl=%2fVentilationDesign%2fsecured%2f

PENNSTATE
College of Engineering

Confined-Space Manure
Ventilation Design Tool

Welcome to the Penn State College of Engineering Confined-Space Ventilation Design Tool

Please enter your email address and password below.

Email Address:

Pasword:

Login

Step 3: Home page.

The screenshot shows a web browser window with the URL <https://ventdesign.agsafety.psu.edu> in the address bar. The page header includes the Penn State College of Engineering logo and the title "Confined-Space Manure Ventilation Design Tool". A user is logged in as "user@email.com" with a "Logout" link. The main content area features a welcome message, a navigation menu on the left, and a 3D CFD simulation of a manure storage tank. The simulation shows a cross-section of the tank with a color-coded temperature or concentration field, ranging from blue (cooler) to red (warmer), and dashed lines indicating airflow patterns. The navigation menu includes links for "Home", "Create new CFD study", "View Results", "Edit Account Info", "Leave Feedback", and "Logout". The "Create new CFD study" link is highlighted with a red box.

Ventilation Design Tool

<https://ventdesign.agsafety.psu.edu>

PENNSTATE
College of Engineering

Confined-Space Manure
Ventilation Design Tool

You are logged in as **user@email.com** ([Logout](#))

Penn State College of Engineering Confined-Space Manure Ventilation Design Tool

Welcome, User. This is your 1st visit.

[Information about this online tool](#)

[Create new CFD study](#)

[View results / Edit studies](#)

[Edit Account Info](#)

[Leave Feedback](#)

[Logout](#)

Ventilation Design

Home

[Create new CFD study](#)

[View Results](#)

[Edit Account Info](#)

[Leave Feedback](#)

[Logout](#)

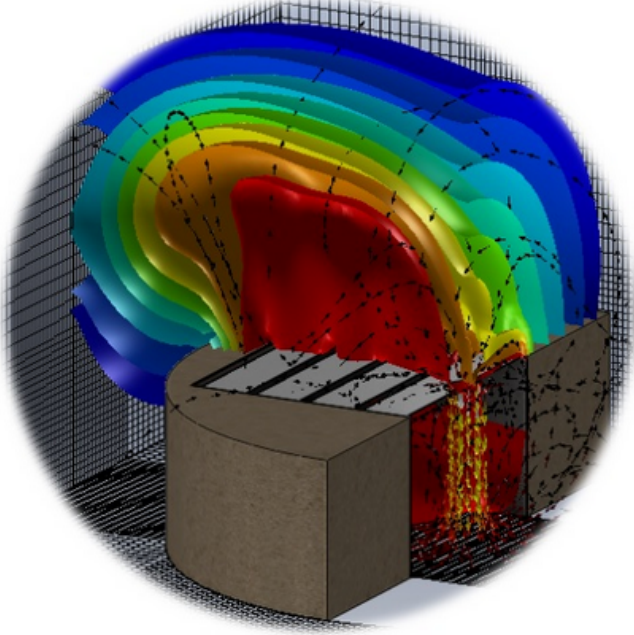

Step 4: Creating a new study.

https://ventdesign.agsafety.psu.edu

PENNSYLVANIA STATE UNIVERSITY
College of Engineering

Confined-Space Manure Ventilation Design Tool
You are logged in as user@email.com (Logout)

Ventilation Design

- Home
- Create new CFD study**
- View Results
- Edit Account Info
- Leave Feedback
- Logout

Create a new CFD Study

You can create a new study by entering the information below or you can copy data from an old study. [Click here to copy an old study](#) or fill in the information below to get started.

Project Name

My Tunnel Ventilated Barn above a Full Sized Manure Pit

Description

Address

Line 1

Line 2

City, State --Select a state--, Zip

Project name is required!

Other details are optional, Scroll down to select pit and barn types.

Step 5: Selecting type of pit and barn.

Ventilation Design Tool x

← → ↻ <https://ventdesign.agsafety.psu.edu/new-cfd-study.aspx> ★ [] [] []

Type of animal Milking Cow Dry Cow Heifer Swine

Number of animals of each type this pit handles

Average animal weight, lbs for each type

Type(s) of bedding used

Check all that apply

Sawdust
 Sand
 Manure Solids
 Gypsum
 Other

Choose pit type

Rectangular

Choose barn type

No Barn Information
 Cross Ventilated
 Naturally Ventilated
 Tunnel Ventilated

← Click here to continue

Manure production and bedding details are optional.

Select Tunnel Ventilated for the barn type.

Step 6: Enter pit fan CFM and pit dimensions.

<https://ventdesign.agsafety.psu.edu>

PENNSTATE
College of Engineering

Confined-Space Manure Ventilation Design Tool
You are logged in as **user@email.com** (Logout)

Ventilation Design

- Home
- Create new CFD study
- View Results
- Edit Account Info
- Leave Feedback
- Logout

Create a new CFD Study: Pit Data

Caution: Input boxes are populated with non-zero default values. Be sure to change these values for your particular configuration!

Check Constraints Generate Preview Save New Study

Pit Geometry

Pit Fan CFM
Pit Fan CFM @ 0.10" SP (enter a value from 1,000 to 10,000 CFM in 500 CFM increments)

Pit Fan Inlet Duct
 Ducted Fresh Air Inlet

Initial Gas Concentration Inside Manure Pit

Hydrogen Sulfide, ppm

Methane, ppm

Nitrogen Dioxide, ppm

Ammonia, ppm

Enter pit fan flow rate here.

Check this box for ducted fresh air.

Scroll down to continue

You can change initial pit gas concentrations here.

Step 6: Enter pit fan CFM and pit dimensions.

https://ventdesign.agsafety.psu.edu

PENNSTATE
College of Engineering

Confined-Space Manure
Ventilation Design Tool
You are logged in as user@email.com (Logout)

Ventilation Design

- Home
- Create new CFD study
- View Results
- Edit Account Info
- Leave Feedback
- Logout

Create a new CFD Study: Pit Data

Caution: Input boxes are populated with non-zero default values. Be sure to change these values for your particular configuration!

Check Constraints Generate Preview Save New Study

Pit Geometry

Rectangular Tank Dimensions

Cover Thickness	0	6
Length	100	0
Width	40	0
Depth	8	0

(X,Y,Z) = (0,0,0)

Scroll down to continue

Step 7: Enter pit fan inlet dimensions.

https://ventdesign.agsafety.psu.edu

PENN STATE
College of Engineering

Confined-Space Manure
Ventilation Design Tool
You are logged in as user@email.com (Logout)

Ventilation Design

- Home
- Create new CFD study
- View Results
- Edit Account Info
- Leave Feedback
- Logout

Create a new CFD Study: Pit Data

Caution: Input boxes are populated with non-zero default values. Be sure to change these values for your particular configuration!

Check Constraints Generate Preview Save New Study

Pit Geometry

Inlet Dimensions

D Inlet Diameter

2	0
97	0
20	0

Barn Fans are located at this end

Barn Airflow

The diagram shows a rectangular pit with various dimensions and offsets. A red circle on the left side represents a fan inlet. A blue arrow labeled 'Barn Airflow' points from the right towards the fan. A green arrow on the right side points downwards. Dimensions include Pit X Length, Pit Y Length, Inlet X Offset, Inlet Y Offset, and offsets for two outlets (Outlet 1 and Outlet 2).

Step 8: Uncheck slotted cover.

http://ventdesign.agsafety.psu.edu

PENNSTATE
College of Engineering

Confined-Space Manure
Ventilation Design Tool
You are logged in as user@email.com (Logout)

Create a new CFD Study: Pit Data

Caution: Input boxes are populated with non-zero default values. Be sure to change these values for your particular configuration!

Check Contraints Generate Preview Save New Study

Pit Geometry

Ducted Fan Outlet

Pit Fan Discharge Elbow

Outlets

Slotted Cover

Slotted Cover Region 1

X Offset
1 2

Y Offset
1 10

X Length
21 10

Y Length
4 0

X Width
0 4

Angle
10

Multiple Slots

Check this box since we have a slotted cover.

The diagram shows a top-down view of a rectangular tank with a slotted cover. The cover consists of three rectangular slots. Labels indicate 'X Width' for the width of a slot, 'X Offset' for the distance from the left edge to the first slot, 'X Spacing' for the distance between adjacent slots, and 'Angle' for the rotation of the slots. A second diagram shows a side view of the tank with a red circle on the cover, labeling 'Tank Y Width' and 'Slot Y Length'.

Manure Pit Cover Details

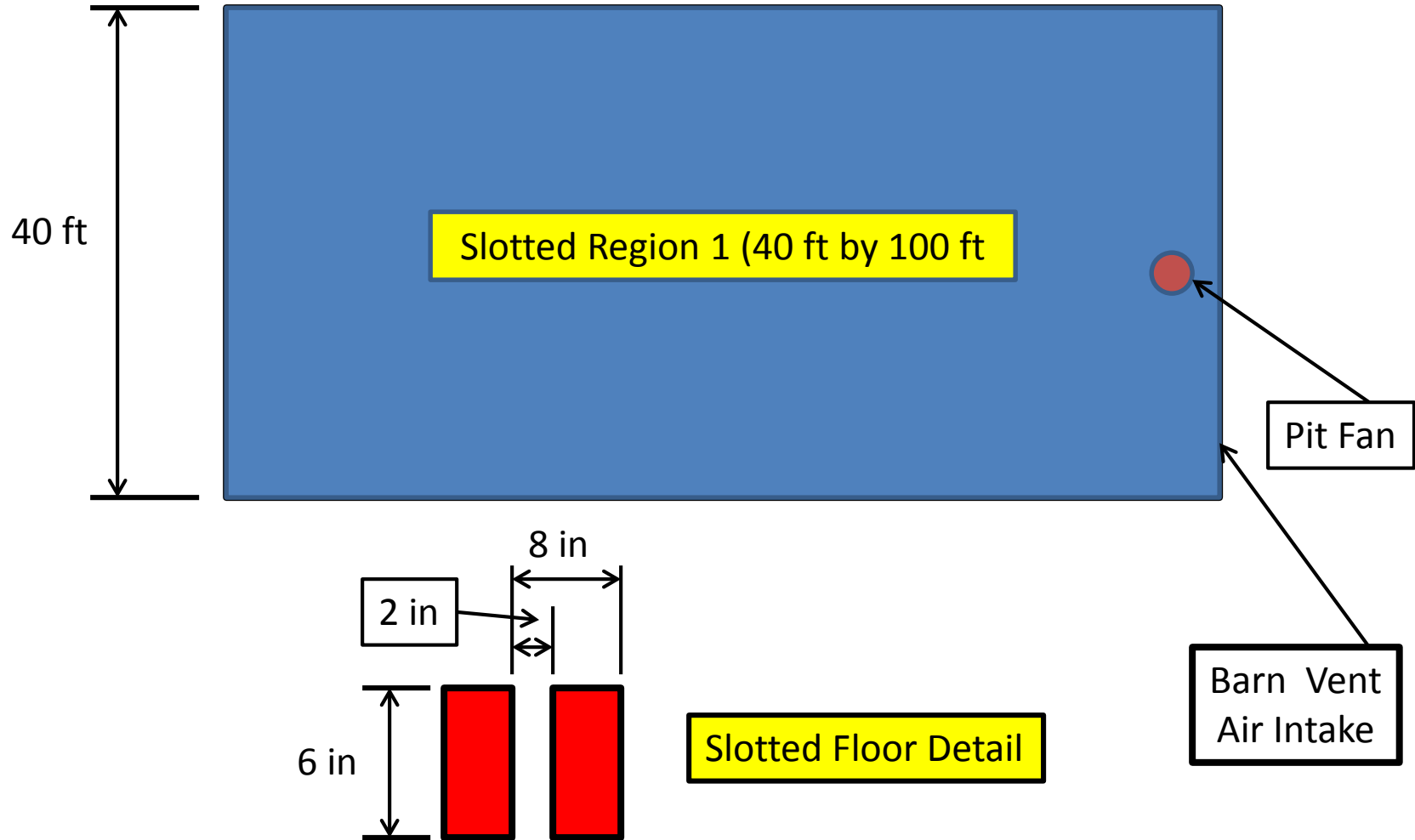

Step 8: Enter slotted cover dimensions.

https://ventdesign.agsafety.psu.edu

PENN STATE
College of Engineering

Confined-Space Manure
Ventilation Design Tool
You are logged in as user@email.com (Logout)

Ventilation Design

- Home
- Create new CFD study
- View Results
- Edit Account Info
- Leave Feedback
- Logout

Create a new CFD Study: Pit Data

Caution: Input boxes are populated with non-zero default values. Be sure to change these values for your particular configuration!

Check Contraints Generate Preview Save New Study

Pit Geometry Barn Geometry Pit+Barn Location

Slotted Cover
 Slotted Cover Region 1

X Offset

Y Offset

X Length

X Width

X Width

Angle

Multiple Slots
X Spacing

Slotted Cover Region 2
 Slotted Cover Region 3
 Slotted Cover Region 4
 Slotted Cover Region 5
 Outlet 1 Dimension

Check this box for Multiple slots

Step 8: Enter additional slotted cover regions as needed.

https://ventdesign.agsafety.psu.edu

PENNSYLVANIA STATE UNIVERSITY
College of Engineering

Confined-Space Manure
Ventilation Design Tool
You are logged in as user@email.com (Logout)

Create a new CFD Study: Pit Data

Caution: Input boxes are populated with non-zero default values. Be sure to change these values for your particular configuration!

Check Contraints Generate Preview Save New Study

Pit Geometry Barn Geometry Pit+Barn Location

Slotted Cover

Slotted Cover Region 1

X Offset
1 2 "

Y Offset
1 10 "

X Length
21 10 "

Y Length
4 0 "

X Width
0 4 "

Angle
10

Multiple Slots

X Spacing
0 8 "

Slotted Cover Region 2

Slotted Cover Region 3

Slotted Cover Region 4

Slotted Cover Region 5

Outlet 1 Dimension

When to check slotted Region 2, 3, 4, or 5

Manure Pit Cover Details

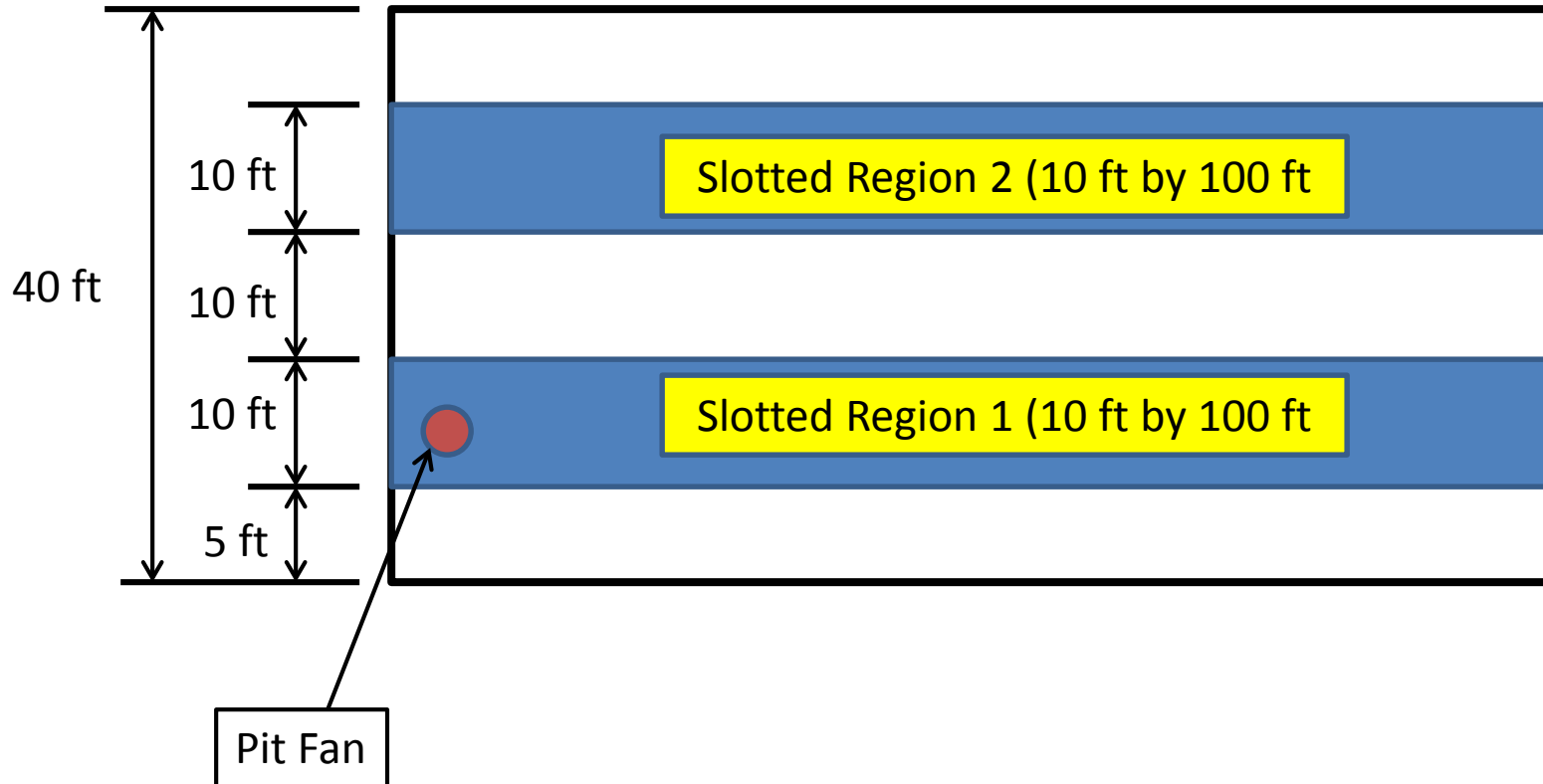

Step 9: Enter barn fan CFM and barn dimensions.

https://ventdesign.agsafety.psu.edu

new-cfd-study-pit-data.aspx?header=1108

ventilation Design Tool
You are logged in as user@email.com (Logout)

Ventilation Design

- Home
- Create new CFD study
- View Results
- Edit Account Info
- Leave Feedback
- Logout

Create a new CFD Study: Pit Data

Caution: Input boxes are populated with non-zero default values. Be sure to change these values for your particular configuration!

Check Constraints Generate Preview Save New Study

Pit Geometry **Barn Geometry** Pit+Barn Location

Barn Fan CFM

Total Barn Fan CFM @

Tunnel Ventilated Barn Dimensions

Eave Height

Y Barn Length

Y Barn Width

Outlet End Offset

Inlet End Offset

Inlet Wall Height

Barn Fans are located at this end

Origin (0,0,0)

Step 9: Enter barn fan CFM and barn dimensions.

https://ventdesign.agsafety.psu.edu

new-cfd-study-pit-data.aspx?header=1108

ventilation Design Tool
You are logged in as user@email.com (Logout)

Ventilation Design

- Home
- Create new CFD study
- View Results
- Edit Account Info
- Leave Feedback
- Logout

Create a new CFD Study: Pit Data

Caution: Input boxes are populated with non-zero default values. Be sure to change these values for your particular configuration!

Check Constraints Generate Preview Save New Study

Pit Geometry **Barn Geometry** Pit+Barn Location

Barn Fan CFM

Total Barn Fan CFM @ 0.10" SP

Tunnel Ventilated Barn Dimensions

Eave Height

X Barn Length

Y Barn Width

Outlet End Offset

Inlet End Offset

Inlet Wall Height

Note: This image can be found by scrolling down

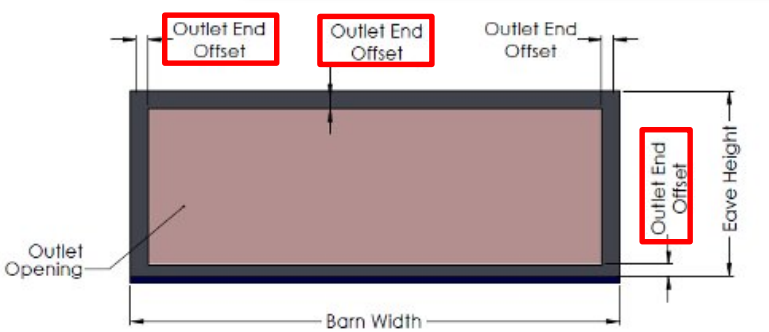

The diagram illustrates a cross-section of a barn with a brown interior. Key dimensions and offsets are labeled: 'Outlet End Offset' (three locations at the top), 'Outlet End Offset' (one location on the right side), 'Eave Height' (on the right), and 'Barn Width' (at the bottom). An 'Outlet Opening' is indicated on the left side of the barn.

Step 9: Enter barn fan CFM and barn dimensions.

https://ventdesign.agsafety.psu.edu

new-cfd-study-pit-data.aspx?header=1108

ventilation Design Tool
You are logged in as user@email.com (Logout)

Ventilation Design

- Home
- Create new CFD study
- View Results
- Edit Account Info
- Leave Feedback
- Logout

Create a new CFD Study: Pit Data

Caution: Input boxes are populated with non-zero default values. Be sure to change these values for your particular configuration!

Check Constraints Generate Preview Save New Study

Pit Geometry **Barn Geometry** Pit+Barn Location

Barn Fan CFM

Total Barn Fan CFM @ 0.10" SP

Tunnel Ventilated Barn Dimensions

Eave Height

X Barn Length

Y Barn Width

Outlet End Offset

Inlet End Offset

Inlet Wall Height

Note: This image can be found by scrolling down

Step 10: Enter Pit+Barn location dimensions.

https://ventdesign.agsafety.psu.edu

PENNSTATE
College of Engineering

Confined-Space Manure
Ventilation Design Tool
You are logged in as user@email.com (Logout)

Create a new CFD Study: Pit Data

Caution: Input boxes are populated with non-zero default values. Be sure to change these values for your particular configuration!

Check Constraints Generate Preview Save New Study

Pit Geometry Barn Geometry **Pit+Barn Location**

Tunnel Ventilated Barn with Rectangular Tank

Pit X Offset
 "

Pit Y Offset
 "

Manure Pit

Barn

Step 10: Enter Pit+Barn location dimensions.

https://ventdesign.agsafety.psu.edu

new-cfd-study-pit-data.aspx?header=1115

ventilation Design Tool
You are logged in as user@email.com (Logout)

Ventilation Design

- Home
- Create new CFD study
- View Results
- Edit Account Info
- Leave Feedback
- Logout

Create a new CFD Study: Pit Data

Caution: Input boxes are populated with non-zero default values. Be sure to change these values for your particular configuration!

Check Constraints Generate Preview Save New Study

Pit Geometry Barn Geometry **Pit+Barn Location**

The diagram illustrates the spatial relationship between a barn and a pit. The barn is represented by a trapezoidal shape at the top, with an arrow indicating the 'Barn airflow direction' pointing to the left. Below the barn is a rectangular area representing the pit. The 'Barn Outline' is shown as a dashed line. The 'Pit' is a solid dark blue rectangle. The 'Barn Origin (0,0)' is marked at the bottom-left corner of the barn's footprint. The 'Pit Origin (0,0)' is marked at the top-left corner of the pit. Dimensions are indicated with arrows: 'Barn Width' and 'Pit Y Width' are vertical dimensions on the left; 'Barn Length' and 'Pit X Length' are horizontal dimensions at the bottom. Two dimensions are highlighted with red boxes: 'Pit Y Offset' is the vertical distance from the Barn Origin to the Pit Origin, and 'Pit X Offset' is the horizontal distance from the Barn Origin to the Pit Origin.

Step 11: Click "Check Constraints" to check your input for errors.

<https://ventdesign.agsafety.psu.edu>

Click the Check Constraints button to check your input for errors.

Confined-Space Manure Ventilation Design Tool
You are logged in as [user@email.com](#) (Logout)

Ventilation Design

- Home
- Create new CFD study
- View Results
- Edit Account Info
- Leave Feedback
- Logout

Create a new CFD Study: Pit Data

Caution: Input boxes are populated with non-zero default values. Be sure to change these values for your particular configuration!

Check Constraints Generate Preview Save New Study

Pit Geometry Barn Geometry Pit+Barn Location

Tunnel Ventilated Barn with Rectangular Tank

Pit X Offset
0' 0"

Pit Y Offset
0' 0"

Generate Preview or Save New Study will also check your input for errors.

Step 11: Click "Check Constraints" to check your input for errors.

The screenshot shows the 'Ventilation Design Tool' web application. The browser address bar displays <https://ventdesign.agsafety.psu.edu>. The page header includes the Penn State College of Engineering logo and the title 'Confined-Space Manure Ventilation Design Tool'. A user is logged in as 'user@email.com'. The main content area is titled 'Create a new CFD Study: Pit Data' and includes a caution: 'Caution: Input boxes are populated with non-zero default values. Be sure to change these values for your particular configuration!'. Below this, there are buttons for 'Please wait while checking constraints...' (highlighted with a red box), 'Generate Preview', and 'Save New Study'. The 'Pit+ Barn Location' tab is active, showing a 3D model of a 'Tunnel Ventilated Barn with Pit'. A 'Working...' dialog box with a loading spinner is overlaid on the 3D model. To the left of the model are input fields for 'Pit X Offset' and 'Pit Y Offset', both set to '0' feet and '0' inches.

Step 11: Click "Check Constraints" to check your input for errors.

https://ventdesign.agsafety.psu.edu

PENNSTATE
College of Engineering

Confined-Space Manure
Ventilation Design Tool
You are logged in as user@email.com (Logout)

Ventilation Design

- Home
- Create new CFD study
- View Results
- Edit Account Info
- Leave Feedback
- Logout

Create a new CFD Study: Pit Data

Caution: Input boxes are populated with non-zero default values. Be sure to change these values for your particular configuration!

Check Constraints Generate Preview Save New Study

Pit Geometry Barn Geometry Pit+ Barn Location

Tunnel Ventilated Barn with Rectangular Tank

Pit X Offset
0' 0" No Constraints

Pit Y Offset
0' 0" No Constraints

Step 12: Click "Generate Preview" to create a 3D PDF for review.

The screenshot shows a web browser window with the URL <https://ventdesign.agsafety.psu.edu> highlighted in a black box. The page title is "Confined-Space Manure Ventilation Design Tool" and the user is logged in as "user@email.com". The interface includes a navigation menu on the left with options like "Home", "Create new CFD study", and "View Results". The main content area is titled "Create a new CFD Study: Pit Data" and contains a red warning: "Caution: Input boxes are populated with non-zero default values. Be sure to change these values for your particular configuration!". Below this, there are three buttons: "Check Constraints", "Generate Preview" (highlighted with a red box), and "Save New Study". There are also three tabs: "Pit Geometry", "Barn Geometry", and "Pit+Barn Location" (the active tab). The main content area displays "Tunnel Ventilated Barn with Rectangular Tank" with input fields for "Pit X Offset" and "Pit Y Offset", both set to "0" with "No Constraints" below them. A 3D perspective view of a rectangular tank is shown on the right.

Step 12: Click "Generate Preview" to create a 3D PDF for review.

https://ventdesign.agsafety.psu.edu

PENNSTATE
College of Engineering

Confined-Space Manure
Ventilation Design Tool
You are logged in as user@email.com (Logout)

Ventilation Design

- Home
- Create new CFD study
- View Results
- Edit Account Info
- Leave Feedback
- Logout

Create a new CFD Study: Pit Data

Caution: Input boxes are populated with non-zero default values. Be sure to change these values for your particular configuration!

Check Constraints **Please wait while input files for the preview are generated...** Save New Study

Pit Geometry Barn Geometry **Pit+Barn Location**

Tunnel Ventilated Barn with Rectangular Tank

Pit X Offset
0' 0" No Constraints

Pit Y Offset
0' 0" No Constraints

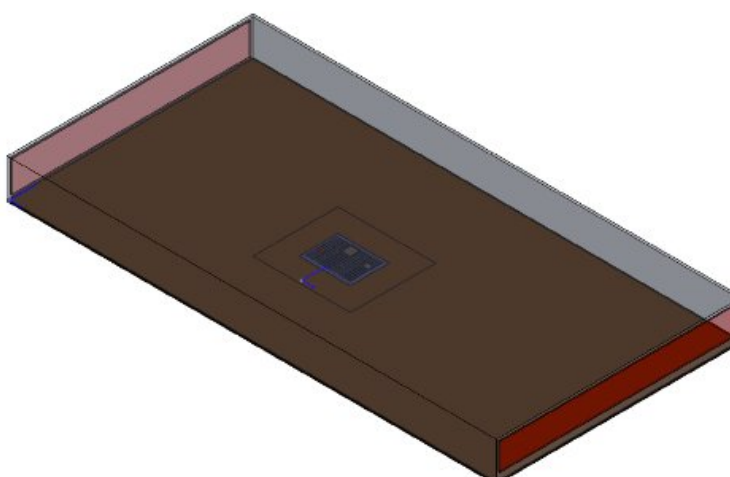

Waiting for www.engr.psu.edu...

Step 12: Click "Generate Preview" to create a 3D PDF for review.

https://ventdesign.agsafety.psu.edu

PENNSTATE
College of Engineering

Confined-Space Manure
Ventilation Design Tool
You are logged in as user@email.com (Logout)

Ventilation Design

- Home
- Create new CFD study
- View Results
- Edit Account Info
- Leave Feedback
- Logout

Create a new CFD Study: Pit Data

Caution: Input boxes are populated with non-zero default values. Be sure to change these values for your particular configuration!

There is a preview for the pit+barn data being prepared.

Check Constraints Generate Preview Save New Study

Pit Geometry Barn Geometry **Pit+Barn Location**

Tunnel Ventilated Barn with Rectangular Tank

Pit X Offset
0' 0" No Constraints

Pit Y Offset
0' 0" No Constraints

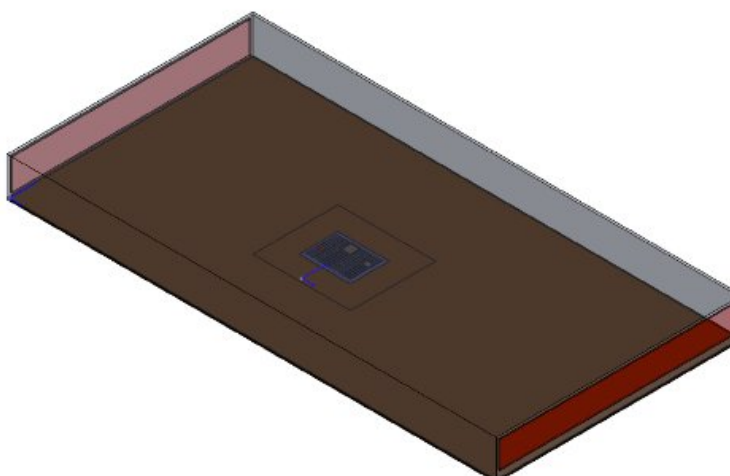

Step 13: Click "View Pit+Barn Preview" to review a 3D PDF for your model.

The screenshot shows a web browser window with the URL <https://ventdesign.agsafety.psu.edu> in the address bar. The page header includes the Penn State College of Engineering logo and the title "Confined-Space Manure Ventilation Design Tool". A navigation menu on the left lists options like "Home", "Create new CFD study", and "View Results". The main content area features a "Create a new CFD Study: Pit Data" section with a red warning: "Caution: Input boxes are populated with non-zero default values. Be sure to change these values for your particular configuration!". Below this, the "View Pit+Barn Preview" link is highlighted with a red box. Other buttons include "Check Constraints", "Generate Preview", "Save New Study", and tabs for "Pit Geometry", "Barn Geometry", and "Pit+Barn Location". The "Pit+Barn Location" tab is active, showing a 3D model of a "Tunnel Ventilated Barn with Rectangular Tank" and input fields for "Pit X Offset" and "Pit Y Offset", both set to 0.

Step 14: Save or open PDF file.

https://ventdesign.agsafety.psu.edu

Enable 3D View

If the PDF does not display correctly above a link directly to the PDF if provided below.

[3-d Preview PDF](#)

Step 14: Save or open PDF file.

The screenshot shows a web browser window with two tabs titled "Ventilation Design Tool". The address bar displays the URL <https://ventdesign.agsafety.psu.edu>. The main content area features a button labeled "Enable 3D View". A context menu is open over the button, with the "Save link as..." option highlighted. Below the button, there is a toolbar with icons for navigation and printing. At the bottom of the page, there is a link labeled "3-d Preview PDF".

https://ventdesign.agsafety.psu.edu

Enable 3D View

- Open link in new tab
- Open link in new window
- Open link in incognito window
- Save link as...
- Copy link address
- Inspect element

If the PDF does not open, click the link directly to the PDF if provided below.

[3-d Preview PDF](#)

Step 14: Viewing the PDF file.

TunnelVentilatedBarnWithRectangularTank_Rev_3D.pdf - Adobe Reader

File Edit View Window Help

Open [Icons] 1 / 1 [Zoom: 82.6%] [Tools: Fill & Sign Comment]

Sign In

- Export PDF
- Create PDF
- Edit PDF

Adobe Acrobat Pro
Easily edit text and images in PDF documents

Start Now

Send Files

You can zoom, rotate, hide or objects or make them transparent, and even change the display style of the model:

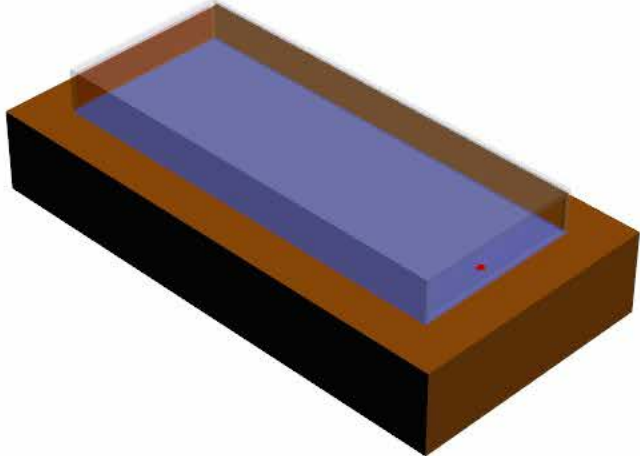

- Zoom using the center mouse wheel.
- Rotate the model by clicking the left mouse button and dragging across the screen.
- Left-click an object to select it, then Right-click for viewing options.
- Close Adobe Reader to exit when finished.

Viewing the 3-D Image of the Manure Pit from Supplemental Results Files (Optional)

- Go to the website <https://ventdesign.agsafety.psu.edu>
- Click on “Supplemental Results Files”
- Select “Module 3”
- Select “Rotating 3D TV Preview.avi”
- Return to this Workshop Module and Resume the Workshop Presentation



Step 15A: How to go back to make changes before saving the study.

The screenshot shows a web browser window with the URL <https://ventdesign.agsafety.psu.edu> in the address bar. The page title is "Confined-Space Manure Ventilation Design Tool" and the user is logged in as "user@email.com". The main content area is titled "Create a new CFD Study: Pit Data" and includes a caution: "Caution: Input boxes are populated with non-zero default values. Be sure to change these values for your particular configuration!". Below this, there are three buttons: "Check Constraints", "Generate Preview", and "Save New Study". The "Pit+ Barn Location" tab is selected, showing a 3D model of a "Tunnel Ventilated Barn with Rectangular Tank". The "Pit X Offset" input field is set to "0".

https://ventdesign.agsafety.psu.edu

Confined-Space Manure Ventilation Design Tool
You are logged in as **user@email.com** ([Logout](#))

Ventilation Design

- Home
- Create new CFD study
- View Results
- Edit Account Info
- Leave Feedback
- Logout

Create a new CFD Study: Pit Data

Caution: Input boxes are populated with non-zero default values. Be sure to change these values for your particular configuration!

Check Constraints Generate Preview Save New Study

Pit Geometry Barn Geometry **Pit+ Barn Location**

Tunnel Ventilated Barn with Rectangular Tank

Pit X Offset
0 0 "

You can go back and make changes at any time before Saving the study if you are not satisfied with your Preview.

Step 15A: How to go back to make changes before saving the study.

The screenshot shows a web browser window with the URL <https://ventdesign.agsafety.psu.edu>. The page title is "Confined-Space Manure Ventilation Design Tool" and the user is logged in as "user@email.com". The main content area is titled "Create a new CFD Study: Pit Data" and includes a caution: "Caution: Input boxes are populated with non-zero default values. Be sure to change these values for your particular configuration!". Below this, there are three tabs: "Pit Geometry", "Barn Geometry", and "Pit+Barn Location". The "Pit+Barn Location" tab is highlighted in light blue. A callout box with a green border and white background contains the following text: "The current tab is highlighted light blue. You can navigate to the other input sections to make changes at any time before Saving the study by clicking on them. No changes can be made after Saving the study." The background shows a 3D model of a tunnel ventilated barn with a rectangular tank.

Step 15B: Click "Save New Study" to save and run the simulation.

The screenshot shows a web browser window with the URL <https://ventdesign.agsafety.psu.edu> highlighted in a black box. The page title is "Confined-Space Manure Ventilation Design Tool" and the user is logged in as "user@email.com". The page features a navigation menu on the left with options like "Home", "Create new CFD study", and "View Results". The main content area is titled "Create a new CFD Study: Pit Data" and includes a red warning: "Caution: Input boxes are populated with non-zero default values. Be sure to change these values for your particular configuration!". Below this, there are three buttons: "Check Constraints", "Generate Preview", and "Save New Study", with the latter being highlighted in a red box. There are also three tabs: "Pit Geometry", "Barn Geometry", and "Pit+Barn Location", with the last one being active. The main content area displays "Tunnel Ventilated Barn with Rectangular Tank" and includes input fields for "Pit X Offset" and "Pit Y Offset", both set to "0" with "No Constraints" below them. A 3D perspective view of a rectangular tank is shown on the right.

Step 15B: Click "Save New Study" to save and run the simulation.

The screenshot shows a web browser window with the URL <https://ventdesign.agsafety.psu.edu> in the address bar. The page header includes the Penn State College of Engineering logo and the title "Confined-Space Manure Ventilation Design Tool". A user is logged in as "user@email.com". A confirmation dialog box is open, asking "Are you sure you want to save this study and generate results?". The dialog has "OK" and "Cancel" buttons. Below the dialog, the "Save New Study" button is highlighted in blue. The main content area shows a 3D model of a "Tunnel Ventilated Barn with Rectangular Tank" and input fields for "Pit X Offset" and "Pit Y Offset", both set to 0 with "No Constraints" below them. A sidebar on the left contains navigation links: Home, Create new CFD study, View Results, Edit Account Info, Leave Feedback, and Logout.

Step 16: Simulation is running...

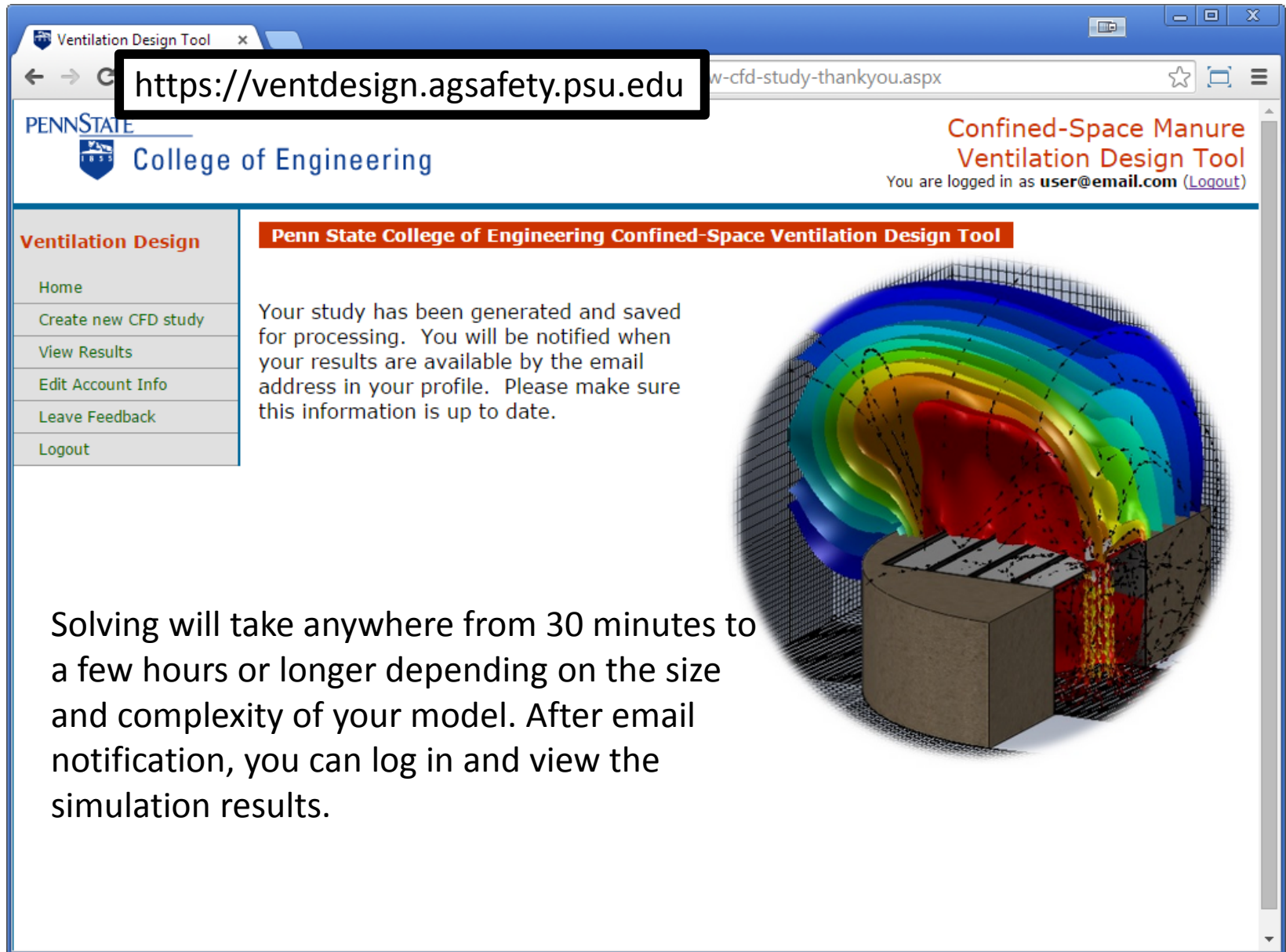

The screenshot shows a web browser window with the URL <https://ventdesign.agsafety.psu.edu> in the address bar. The page header includes the Penn State College of Engineering logo and the title "Confined-Space Manure Ventilation Design Tool". A notification message states: "Your study has been generated and saved for processing. You will be notified when your results are available by the email address in your profile. Please make sure this information is up to date." To the right of the text is a 3D visualization of a simulation, showing a cross-section of a structure with a fire source and a color-coded flow field representing air movement. A sidebar on the left contains navigation links: Home, Create new CFD study, View Results, Edit Account Info, Leave Feedback, and Logout.

Ventilation Design

- Home
- Create new CFD study
- View Results
- Edit Account Info
- Leave Feedback
- Logout

Penn State College of Engineering Confined-Space Ventilation Design Tool

Your study has been generated and saved for processing. You will be notified when your results are available by the email address in your profile. Please make sure this information is up to date.

Solving will take anywhere from 30 minutes to a few hours or longer depending on the size and complexity of your model. After email notification, you can log in and view the simulation results.

Step 13: Log in, click “View your results” link.

The screenshot shows a web browser window with the URL <https://ventdesign.agsafety.psu.edu> in the address bar. The page header includes the Penn State College of Engineering logo and the title "Confined-Space Manure Ventilation Design Tool". A user is logged in as "user@email.com" with a "Logout" link. A left sidebar menu lists options: Home, Create new CFD study, View Results (highlighted with a red box), Edit Account Info, Leave Feedback, and Logout. The main content area features a welcome message, a link to "Information about this online tool", and a list of actions: Create new CFD study, View results / Edit studies (highlighted with a red box), Edit Account Info, Leave Feedback, and Logout. On the right, a 3D CFD simulation shows a cross-section of a manure storage structure with a fire source at the bottom, illustrating air flow patterns and temperature gradients.

Step 17: Click "View Results" button.

The screenshot shows a web browser window with the URL <https://ventdesign.agsafety.psu.edu> in the address bar. The page title is "Confined-Space Manure Ventilation Design Tool" and the user is logged in as "user@email.com". The page features a navigation menu on the left and a main content area with a table of studies.

Ventilation Design

- Home
- Create new CFD study
- View Results**
- Edit Account Info
- Leave Feedback
- Logout

View results / edit unprocessed studies

Name	Status	Original Submission Date	
My Stand-alone Pit	Results are ready	4/22/2015	Review Study View Results Delete
My Tunnel Ventilated Barn above a Full Sized Manure Pit	Results are ready	4/24/2015	Review Study View Results Delete

Step 18: Expand the results folder.

<https://ventdesign.agsafety.psu.edu>

Penn State College of Engineering

Confined-Space Manure Ventilation Design Tool

You are logged in as **user@email.com** ([Logout](#))

Ventilation Design

- Home
- Create new CFD study
- View Results
- Edit Account Info
- Leave Feedback
- Logout

Penn State College of Engineering Confined-Space Ventilation Design Tool

To view your results click the [+] sign next to the Results folder below. If you want to download a file click on the file name.

Results

Refer to the images below for animated cut plot color legends and locations: (Scroll down for more)

Volume Fraction of Gas (ppm)	Oxygen (%)
Hydrogen Sulfide (H₂S) Safe at or below (NIOSH)	Oxygen (O₂) Safe at or above (OSHA)
Methane (CH₄) Safe at or below (OSHA)	
Carbon Dioxide (CO₂) Safe at or below (NIOSH)	
Ammonia (NH₃) Safe at or below (NIOSH)	

gnt, Pione Q3
gnt, Midplane

Step 19: Click results file to download and open.

<https://ventdesign.agsafety.psu.edu>

Penn State College of Engineering

Confined-Space Manure Ventilation Design Tool

You are logged in as [user@email.com](#) (Logout)

Ventilation Design

- Home
- Create new CFD study
- View Results
- Edit Account Info
- Leave Feedback
- Logout

Penn State College of Engineering Confined-Space Ventilation Design Tool

To view your results click the [+] sign next to the Results folder below. If you want to download a file click on the file name.

Results

- Animation 6in Above Floor CH4 Contours.avi
- Animation 6in Above Floor CO2 Contours.avi
- Animation 6in Above Floor H2S Contours.avi
- Animation 6in Above Floor NH3 Contours.avi
- Animation 6in Above Floor O2 Contours.avi
- Animation Front Pit Midplane CH4 Contours.avi
- Animation Front Pit Midplane CO2 Contours.avi
- Animation Front Pit Midplane H2S Contours.avi
- Animation Front Pit Midplane NH3 Contours.avi
- Animation Front Pit Midplane O2 Contours.avi
- Animation Front Pit Plane Q3 CH4 Contours.avi
- Animation Front Pit Plane Q3 CO2 Contours.avi
- Animation Front Pit Plane Q3 H2S Contours.avi
- Animation Front Pit Plane Q3 NH3 Contours.avi
- Animation Front Pit Plane Q3 O2 Contours.avi
- Animation Top Midplane CH4 Contours.avi
- Animation Top Midplane CO2 Contours.avi
- Animation Top Midplane H2S Contours.avi
- Animation Top Midplane NH3 Contours.avi
- Animation Top Midplane O2 Contours.avi
- ResultsFile.xlsx**

Refer to the images below for animated cut plot color legends and locations:
(Scroll down for more)

Volume Fraction of Gas (ppm)

- Hydrogen Sulfide (H₂S)**: Scale 0-100. Safe at or below (NIOSH): 10 ppm.
- Methane (CH₄)**: Scale 0-50,000. Safe at or below (OSHA): 5,000 ppm.
- Carbon Dioxide (CO₂)**: Scale 0-40,000. Safe at or below (NIOSH): 4,000 ppm.
- Ammonia (NH₃)**: Scale 0-300. Safe at or below (NIOSH): 30 ppm.
- Oxygen (O₂)**: Scale 0-19.5%. Safe at or above (OSHA): 19.5%.

Click the file name to open or download the file.

Step 19: Interpreting results for Pit H₂S worksheet.

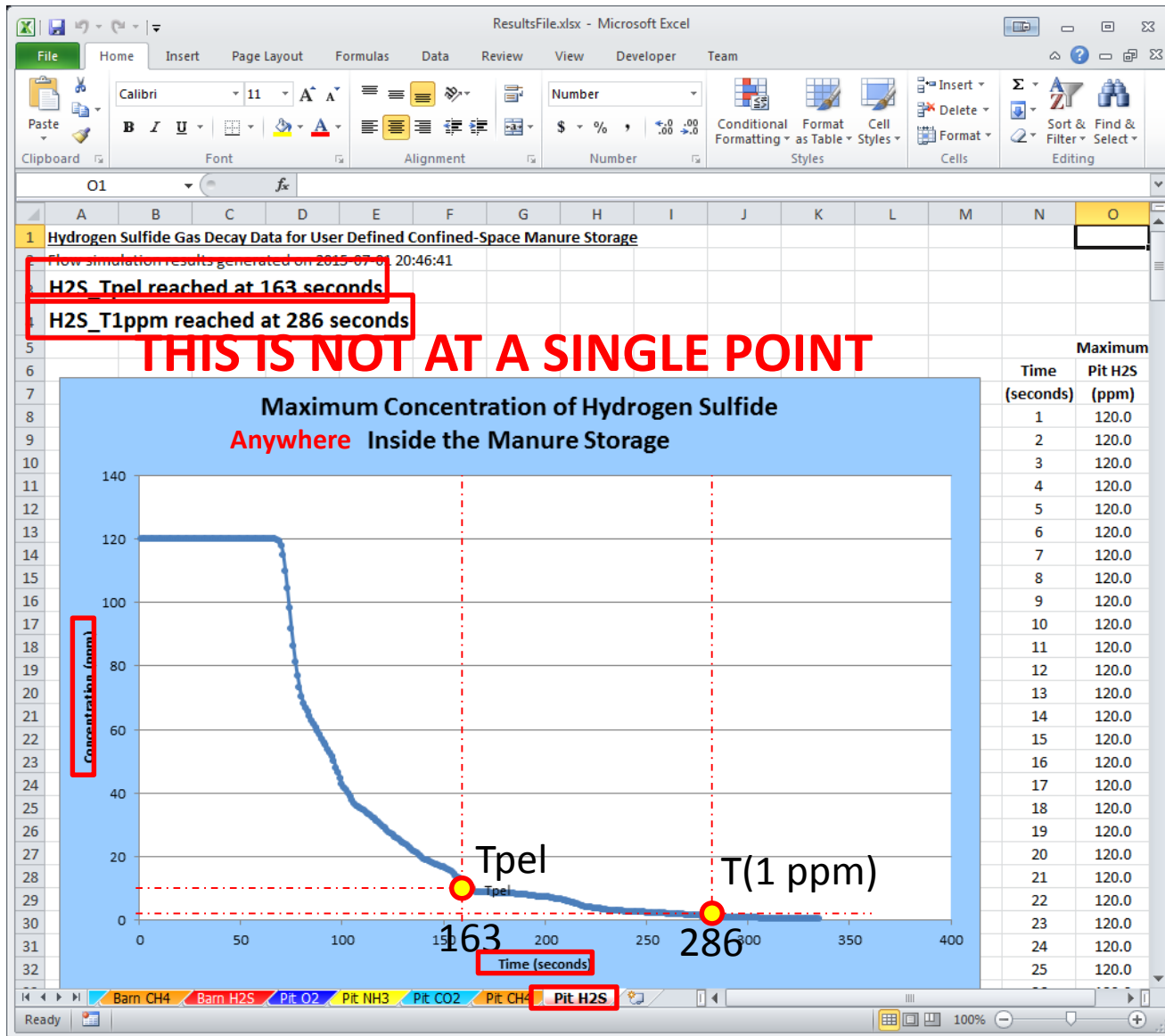

Step 20: Interpreting results for Barn H₂S worksheet.

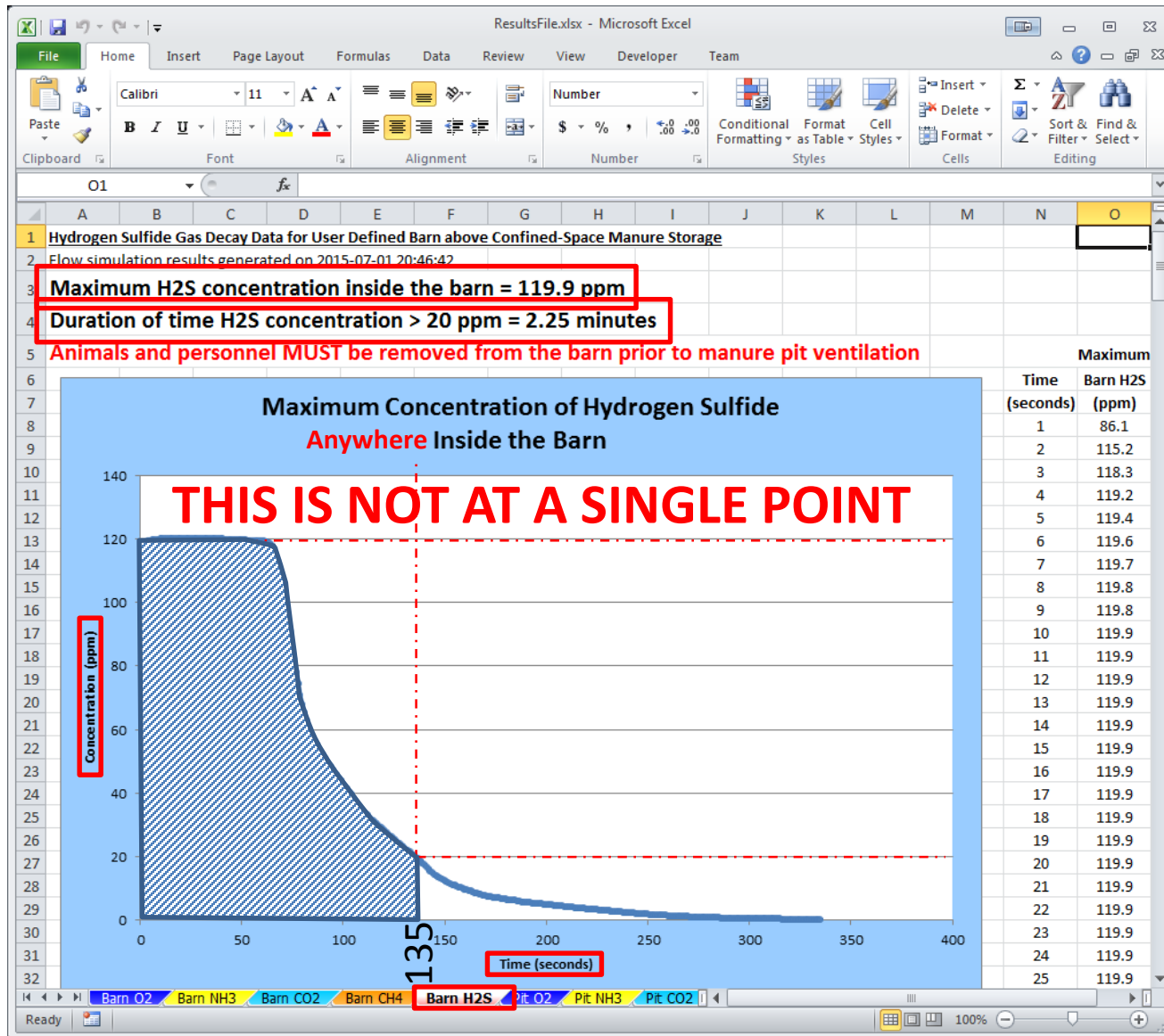

Step 21A: Viewing results for Pit O₂ worksheet.

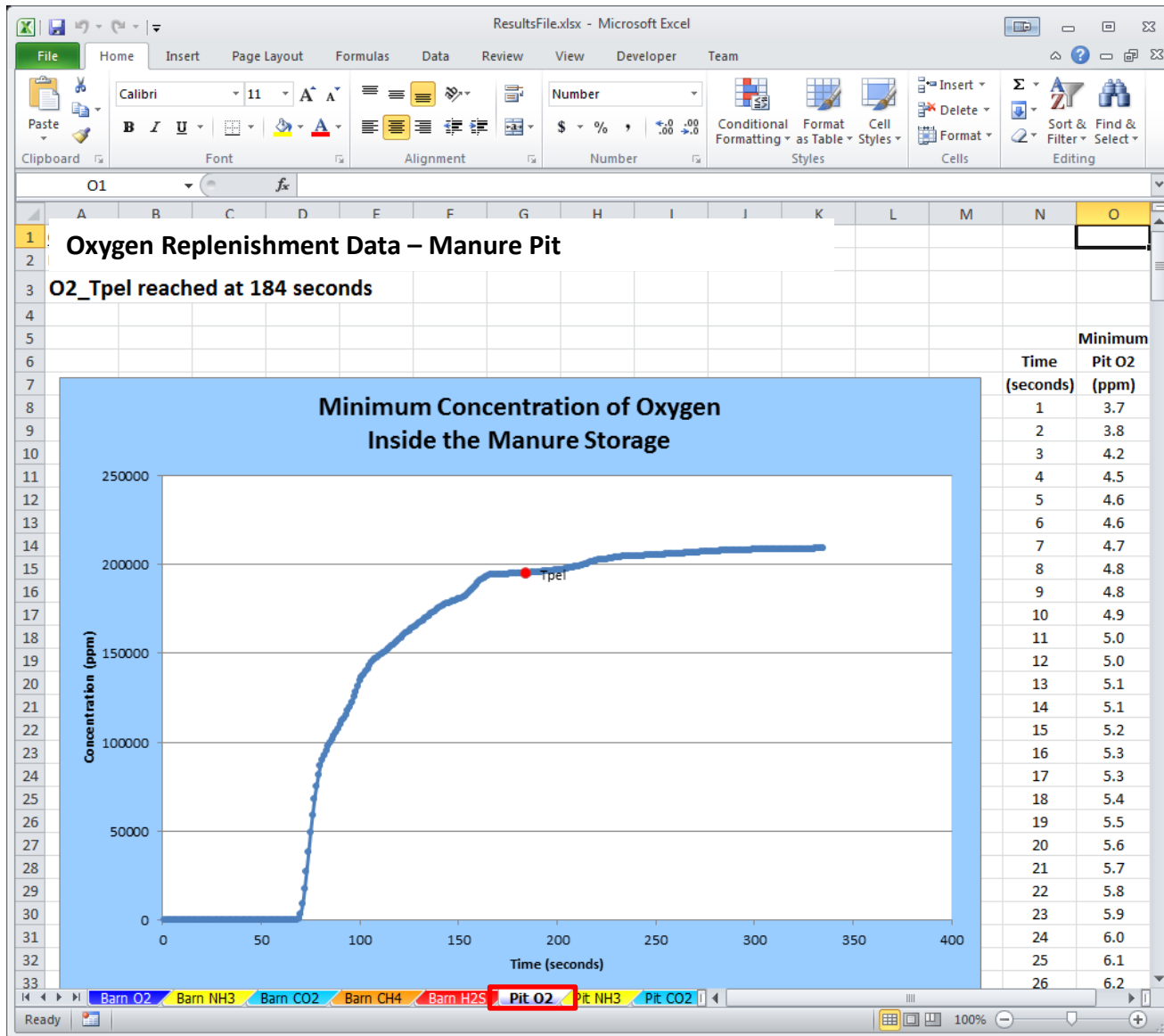

Step 25: Click results file to download and open.

<http://ventdesign.agsafety.psu.edu>

Penn State College of Engineering

Confined-Space Manure Ventilation Design Tool

You are logged in as [user@email.com](#) (Logout)

Ventilation Design

- Home
- Create new CFD study
- View Results
- Edit Account Info
- Leave Feedback
- Logout

Penn State College of Engineering Confined-Space Ventilation Design Tool

To view your results click the [+] sign next to the Results folder below. If you want to download a file click on the file name.

Results

- Animation 6in Above Floor CH4 Contours.avi
- Animation 6in Above Floor CO2 Contours.avi
- Animation 6in Above Floor H2S Contours.avi
- Animation 6in Above Floor NH3 Contours.avi
- Animation 6in Above Floor O2 Contours.avi
- Animation Front Pit Midplane CH4 Contours.avi
- Animation Front Pit Midplane CO2 Contours.avi
- Animation Front Pit Midplane H2S Contours.avi**
- Animation Front Pit Midplane NH3 Contours.avi
- Animation Front Pit Midplane O2 Contours.avi
- Animation Front Pit Plane Q3 CH4 Contours.avi
- Animation Front Pit Plane Q3 CO2 Contours.avi
- Animation Front Pit Plane Q3 H2S Contours.avi
- Animation Front Pit Plane Q3 NH3 Contours.avi
- Animation Front Pit Plane Q3 O2 Contours.avi
- Animation Top Midplane CH4 Contours.avi
- Animation Top Midplane CO2 Contours.avi
- Animation Top Midplane H2S Contours.avi
- Animation Top Midplane NH3 Contours.avi
- Animation Top Midplane O2 Contours.avi
- ResultsFile.xlsx

Refer to the images below for animated cut plot color legends and locations:
(Scroll down for more)

Volume Fraction of Gas (ppm)

Gas	Scale (ppm)	Safe Level
Hydrogen Sulfide (H ₂ S)	0 to 100	Safe at or below (NIOSH): 10 ppm
Methane (CH ₄)	0 to 50,000	Safe at or below (OSHA): 5,000 ppm
Carbon Dioxide (CO ₂)	0 to 40,000	Safe at or below (NIOSH): 4,000 ppm
Ammonia (NH ₃)	0 to 300	Safe at or below (NIOSH): 30 ppm
Oxygen (O ₂)	0% to 19.5%	Safe at or above (OSHA): 19.5%

Click the file name to open or download the file.

Step 26: Viewing the animated cut plot and using the correct color legend.

<http://ventdesign.agsafety.psu.edu>

Penn State College of Engineering Confined-Space Ventilation Design Tool

To view your results click the [+] sign next to the Results folder below. If you want to download a file click on the file name.

Refer to the images below for animated cut plot color legends and locations: (Scroll down for more)

Volume Fraction of Gas (ppm)	Oxygen (%)
Hydrogen Sulfide (H₂S) Scale: 0 to 100 ppm Safe at or below (NIOSH): 10 ppm	Oxygen (O₂) Scale: 0% to 19.5% Safe at or above (OSHA): 19.5%
Methane (CH₄) Scale: 0 to 50,000 ppm Safe at or below (OSHA): 5,000 ppm	
Carbon Dioxide (CO₂) Scale: 0 to 40,000 ppm Safe at or below (NIOSH): 5,000 ppm	
Ammonia (NH₃) Scale: 0 to 300 ppm Safe at or below (NIOSH): 30 ppm	

Example animated results for H₂S

6" Above Floor

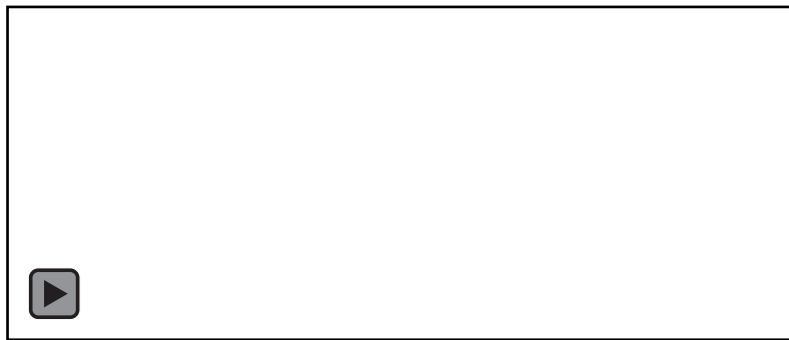

Front Plane Q3

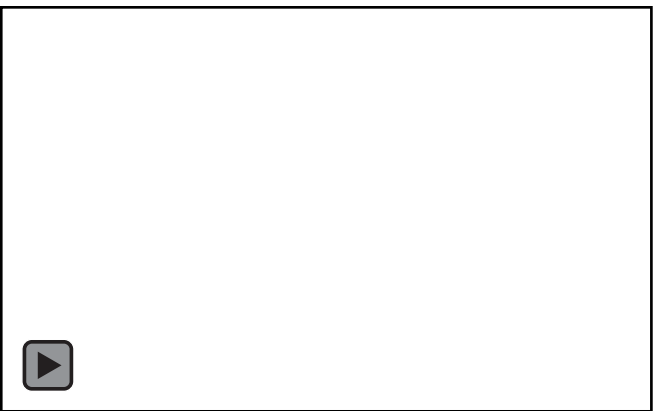

Top Midplane

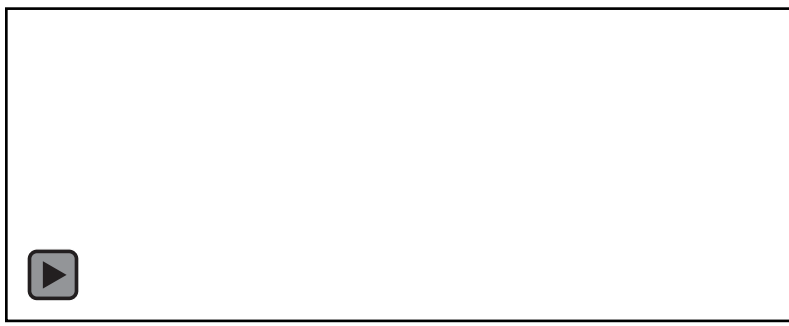

Front Midplane

Viewing ALL the TV Example Results from the Supplemental Results Files (Optional)

- Go to the website <https://ventdesign.agsafety.psu.edu>
- Click on “Supplemental Results Files”
- Select “Module 3”
- Select “Results Files” to view decay curves or the desired cut plot animation(s)



All optional pit features can be added to this very simple example

- Pumpout annexes
- Divider walls
- Obstructions
- Etc.

ONLINE WORKSHOP

<https://ventdesign.agsafety.psu.edu>

Introduction and Logistics

Module 1: Overview

Module 2: Standalone Manure Pits

Module 3: Tunnel-Ventilated Barns above Manure Pits

Module 4: Cross-Ventilated Barns above Manure Pits

Module 5: Student Project 1

Module 6: Naturally-Ventilated Barns above Manure Pits

Module 7: Student Project 2



Penn State Extension

ONLINE TOOL FOR DESIGNING VENTILATION SYSTEMS TO REDUCE MANURE PIT ENTRY RISK

Questions or comments?

